

Turbine Meters

TRZ 03 – TRZ 03-L – TRZ 03-K

Operating Instructions



TRZ 03



TRZ 03-L



TRZ 03-K

RMG Messtechnik GmbH

Otto-Hahn-Strasse 5 · D-35510 Butzbach (Germany)
P.O.Box 280 · D-35502 Butzbach (Germany)
Tel.: +49 (0)6033 897-0 · Fax: (06033) 897-130



Status: 12/2007

Reliability in gas supply –
single-sourced across the board!

Contents

Introduction	1
Scope of application	1
Method of operation and principle of measurement	2
Approvals	3
Standards / Guidelines	3
Validity of meter proving	3
Measuring ranges.....	4
Extension of the measuring range.....	4
Accuracy of measurement.....	5
Temperature ranges.....	5
Pressure loss.....	6
Pressure tap.....	6
Using gas meters with different types of gases.....	7
Safety Instructions	8
Installation and Commissioning	9
Installation	9
Types of totalizers	16
Pulse transmitters.....	21
Temperature measurement.....	25
Commissioning.....	26
Operation	27
Influences on the error of measurement due to operation	27
Lubrication.....	29
Maintenance instructions.....	32
Labelling	32
Specifications	35
Measuring ranges / Dimensions / Pressure classes of the TRZ 03	35
Measuring ranges / Dimensions / Pressure classes of the TRZ 03-L	36
Measuring ranges / Dimensions / Pressure classes of the TRZ 03-K.....	37
Q_{\min} depending on the operating pressure in natural gas.....	38
Overview of the materials used	39
Annex	41

Introduction

Scope of application

The TRZ 03, TRZ 03-E and TRZ 03-L turbine meters are flow meters which can be used for custody transfer metering. Unlike these instruments, the TRZ 03-K turbine meter can only be used for secondary metering. All three types of turbine meters measure the quantity of gas flowing through them in units of volume at prevailing pressure and temperature. Therefore, the units of volume are determined at flowing conditions. The volume of the gas flowing through is indicated by a mechanical totalizer in cubic meters at flowing conditions. In addition, the turbine meters can be fitted with HF or LF pulse transmitters and with reed contacts. In this way, pulses are obtained whose number is proportional to the volume which has flowed through. These pulses can be further processed by volume correctors.

The major differences between types TRZ 03, TRZ 03-E, TRZ 03-K or TRZ 03-L are as follows:

TRZ 03

- Approved for custody transfer metering in compliance with DIN 33800.
- Installation length: 3 x DN
- Accuracy $\leq \pm 0.5\%$ (above $0.2 Q_{max}$)
- Blade monitoring system

TRZ 03-E

- Only with electronic pick-off, without mechanical totalizer.
- Approved for custody transfer metering in compliance with DIN 33800.
- Installation length: 3 x DN
- Accuracy $\leq \pm 0.5\%$ (above $0.2 Q_{max}$)
- Blade monitoring system

TRZ 03-K

- For secondary metering.
- Installation length: $\leq 1.5 \times DN$
- Accuracy $\leq \pm 1\%$ (above $0.2 Q_{max}$)

TRZ 03-L

- Approved for custody transfer metering in compliance with TR G13 / OIML.
- Requires no additional inlet pipe even in the case of heavy flow disturbances.
- Accuracy $\leq \pm 0.5\%$ (above $0.2 Q_{max}$)
- Blade monitoring system

The following applies to all meter types:

- Maximum operating pressure: 100 bar (not for gas meters with a plastic turbine wheel)
- Meter sizes from G 40 to G 16000
- Measuring range 1:20; 1:30 or 1:50 (see data sheets)
- Connections in compliance with DIN or ANSI are available.
- Special designs for aggressive gases are available.
- Available for low temperatures ($< 10^{\circ}\text{C}$)
- All gas meters can be operated in any position up to the nominal diameter of DN 200.

Method of operation

The method of operation of the mechanical turbine meter is based on the measurement of the gas velocity. The velocity of the gas flowing through the gas meter is increased in the flow straightener and the gas strikes the turbine wheel in a defined flow cross section. In the flow straightener, unwanted vortices, turbulences and asymmetries are removed or reduced. The turbine wheel is mounted axially, while the blades of the turbine wheel are arranged at a certain angle to the gas flow. Within the measuring range (Q_{\min} - Q_{\max}), the rotational speed of the turbine wheel is almost proportional to the mean gas velocity and, therefore, to the rate of flow. The number of rotations is a measure of the volume that has flowed through. The rotary movement of the turbine wheel is transmitted by a magnetic coupling to the unpressurized meter head. Downstream of the coupling, there is an HF pulse transmitter (HF 1) and gearing which reduces the rotational speed of the turbine wheel to match the mechanical totalizer. An LF pulse transmitter (slot-type initiator or reed contact) is located on the totalizer. The rotary movement of the turbine wheel is transmitted by a magnetic coupling to the unpressurized meter head. Downstream of the coupling, there is an HF pulse transmitter (HF 1) and gearing which reduces the rotational speed of the turbine wheel to match the mechanical totalizer. An LF pulse transmitter (slot-type initiator or reed contact) is located on the totalizer.

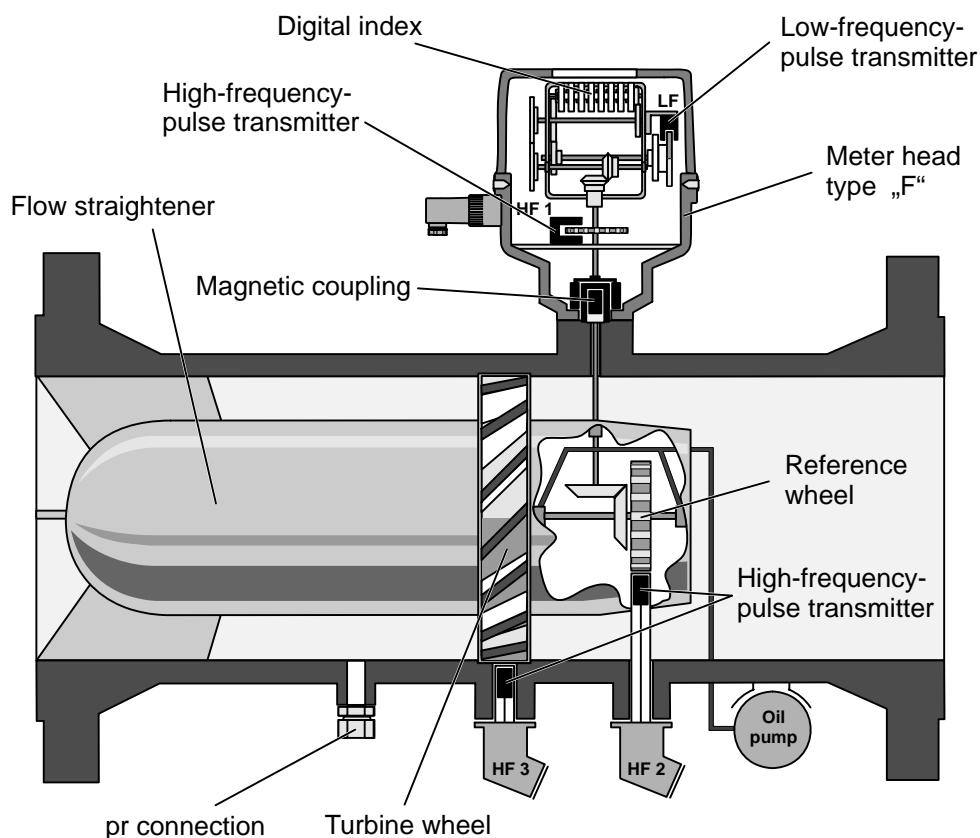

Fig. 1: Sectional drawing of a turbine meter

Downstream of the turbine wheel, a cam wheel (reference wheel) is located on the same shaft. Two HF sensors (proximity switches) generate a signal if a blade of the turbine wheel (HF 3) or a cam of the reference wheel (HF 2) passes them. In this way, two pulse sequences are generated which are out of phase. The generated pulses can be further processed for secondary volume measurements or flow measurements.

Approvals

Type **TRZ 03** has been approved for custody transfer metering.

The following approvals have been obtained:

EU approval	No. D 81.7.21100.10
German approval	No. 7.211/93.06
DVGW registration	No. CE-0085BN0291

Type **TRZ 03-K** has not been approved for custody transfer metering.

The following approvals have been obtained:

DVGW registration	No. CE-0085BN0292
-------------------	-------------------

Type **TRZ 03-L** has been approved for custody transfer metering.

The following approvals have been obtained:

EU approval	No. D 98.7.2110.19
German approval	No. 7.211/98.11
DVGW registration	No. CE-0085BN0291

Standards / Guidelines

All RMG turbine meters have passed the disturbance measurements in compliance with OIML Recommendation IR-32/89, Annex A, with slight and heavy flow disturbances. Therefore, this meter design meets the requirements for installation in compliance with Technical Guideline G 13¹⁾, Sec. 1. Test specifications are as laid down in PTB Testing Instructions, Vol. 4, Volume gas meters, 2nd revised edition of 1992.

The RMG turbine meters of type TRZ 03 comply with DIN 33800.

Validity of meter proving

The turbine meters of type TRZ 03 which are suitable for custody transfer metering must be subjected to subsequent meter proving at regular intervals. The validity of meter proving is determined in the German Metering and Calibration Rules issued in 1988 (with amendment of September 24, 1992) and extends to eight years for turbine meters without a lubricator. Since all RMG TRZ 03 turbine meters are fitted with a lubricator as standard, the following periods apply to subsequent meter proving:

G 40	to G 2500	12 years
G 4000	to G 6500	16 years
G 10000	and larger	without limitation

Note: these periods are valid for Germany, in other countries the periods are normally different!

In the case of subsequent meter proving, the gas meter must be removed and tested on a test rig.

¹⁾ can be ordered at PTB, Bundesallee 100, D-38116 Braunschweig (www.ptb.de)

Measuring ranges

The measuring ranges are between 10 and 25,000 m³/h (flowing conditions). A measuring range is specified for each meter size. It is limited by the minimum flow rate Q_{\min} and the maximum flow rate Q_{\max} (see tables on pages 34 to 36).

For types TRZ 03 and TRZ 03-L, this is the flow range where the gas meter must indicate correct values within the error limits specified by the German Metering and Calibration Rules.

Turbine meters of type TRZ 03 have measuring ranges up to 1:30 even under atmospheric pressure. If a high-pressure test is conducted in compliance with Technical Guideline G 7¹⁾ (PTB), the measuring range can be extended to 1:50. Then the minimum flow rate $Q_{\min, HP}$ is the lowest test point during high-pressure testing. Types TRZ 03 and TRZ 03-L may then be used for billing purposes within the specified HP flow and density ranges.

The measuring range of type TRZ 03-K is 1:16.

Extension of the measuring range

In the range of $0.2 Q_{\max}$ to Q_{\max} , the measuring behaviour of turbine meters is determined by the aerodynamic conditions in the flow channel and the measuring cross section. By means of many series of tests conducted both under atmospheric pressure and under higher pressures and with an appropriate rating for such ranges, it is possible to achieve a deviation of the calibration curve under atmospheric conditions and under high-pressure conditions of < 0.5% in the flow range of $0.2 Q_{\max}$ to Q_{\max} . In the lower flow range, the measuring behaviour is determined by the relationship between the gas flow driving the measuring wheel and the slowing-down torques due to drags (bearings and totalizer). The driving torques increase linearly with the density and quadratically with the velocity of the gas to be measured. Due to the physical conditions, the measuring range is therefore enlarged in relation to the density. The lower flow limit shifts in the direction of smaller loads (see also the table on page 38).

Use the formula below as approximate equation:

$$Q_{\text{mfl}} \approx Q_{\min} \times \sqrt{\frac{1.2}{\rho}} \text{ (m}^3/\text{h)}$$

The density ρ can be determined with the following approximate formula:

$$\rho \approx (p_m + 1) \times \rho_n \text{ (kg/m}^3\text{)}$$

The influence of the temperature is not taken into account in this formula.

Q_{mfl} :	Minimum flow rate at flowing conditions
Q_{\min} :	Minimum flow rate of the gas meter
p_m :	Operating pressure in bar
ρ :	Density in kg/m ³
ρ_n :	Standard density of the gas
	$\rho_n = \text{standard density of natural gas} \approx 0.8 \text{ kg/m}^3$
1.2	Density of air at 20°C and 1.01325 bar (in kg/m ³)

¹⁾ can be ordered at PTB, Bundesallee 100, D-38116 Braunschweig (www.ptb.de)

Accuracy of measurement

The following error limits apply within the permissible measuring range:

Measuring range:	Q_{\min} to $0.2 Q_{\max}$	$0.2 Q_{\max}$ to Q_{\max}
Calibration limit ¹⁾	$\pm 2 \%$	$\pm 1 \%$
TRZ 03, TRZ 03-L	$\pm 1 \%$	$\pm 0.5 \%$
TRZ 03-K	$\pm 2 \%$ ²⁾	$\pm 1 \%$

¹⁾ Permissible maximum error pursuant to the German Metering and Calibration Rules

²⁾ DN 40 and DN 50: -3%, +2%

It will be checked whether these limits are observed. They also apply to the high-pressure range.

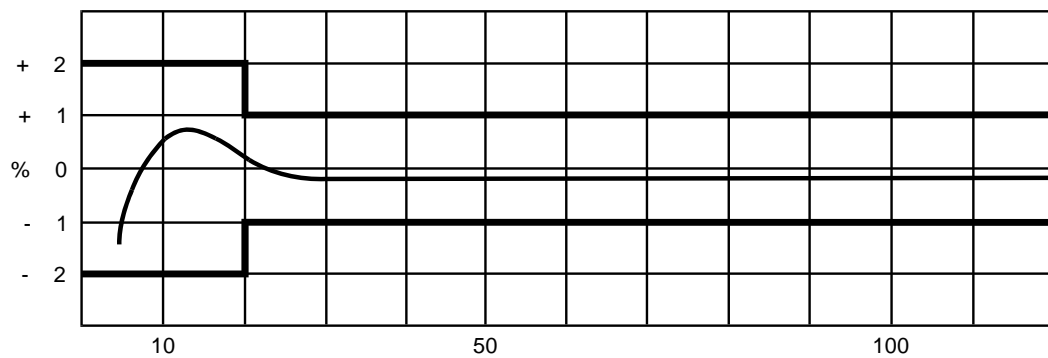

Fig. 1: Calibration curve of a turbine meter

The reproducibility, i.e. the difference between the results of two measurements under identical conditions, is as follows:

TRZ 03:	$\leq \pm 0.2\%$
TRZ 03-K:	$\leq \pm 0.5\%$
TRZ 03-L:	$\leq \pm 0.2\%$

Temperature ranges

For the standard designs of the turbine meters of types TRZ 03, TRZ 03-L and TRZ 03-K, the following fluid temperature and ambient temperature ranges are permitted:

Fluid temperature range:

-10°C to +50°C	(TRZ 03 and TRZ 03-L for custody transfer metering)
-10°C to +60°C	(TRZ 03, TRZ 03-L and TRZ 03-K for secondary metering)

Ambient temperature range:

-10°C to +60°C	(TRZ 03, TRZ 03-L and TRZ 03-K)
----------------	---------------------------------

Pressure loss

The pressure loss of RMG turbine meters has been reduced to a minimum thanks to modifications with regard to design. The measuring points for pressure loss are located 1 x DN upstream and downstream of the gas meter. The pressure loss is calculated using the following formula:

$$\Delta p = Z_p \cdot \rho \cdot \frac{Q_m^2}{DN^4}$$

where:

Δp	is the pressure loss	[mbar]
Z_p	is the pressure loss coefficient	
ρ	is the density	[kg/m ³]
Q_m	is the volume flow rate at measurement conditions	[m ³ /h]
DN	is the nominal diameter of the gas meter	[mm]

Device type	Z_p
TRZ 03 / TRZ 03-K turbine meter	3000
TRZ 03-L turbine meter	3600
L1 perforated-plate straightener as per ISO/DIN	3150
L2 perforated-plate straightener as per ISO/DIN	6300
L3 perforated-plate straightener as per ISO/DIN	9450
LP-35 perforated-plate straightener as per RMG standard	1260
RB 19 tube-bundle straightener as per ISO/DIN	1260

The values for Z_p are approximate mean values. The exact value is calculated from the pressure loss which is determined on testing the volumeter.

Example of calculation:

Calculation of the pressure loss for a turbine meter with upstream perforated-plate straightener.

TRZ 03, $Q_m = 650 \text{ m}^3/\text{h}$, DN 150, $\rho = 1.3 \text{ kg/m}^3$ (natural gas)

From the table: $Z_{p(\text{TRZ03})} = 3000$, $Z_{p(\text{LP-35})} = 1260$

Calculation:

$$Z_{p(\text{total})} = 3000 + 1260 = 4260 \quad \Rightarrow \quad \Delta p = 4260 \cdot 1.3 \cdot \frac{650^2}{150^4} = 4.6 \text{ mbar}$$

Pressure tap

A pressure tap has been provided to connect the pressure transducer of a volume corrector or a pressure gauge to read the pressure at measurement conditions prevailing inside the gas meter. This pressure tap is identified by "p_r".

Using gas meters with different types of gases

Gas type	Symbol	Density at 0°C 1.013 bar	Meter case	Comments
Acetylene	C ₂ H ₄	1.17	Special	Aluminium parts are to be lined with PTFE.
Acid gas			Special	Special measuring element
Air		1.29	Standard	
Ammonia	NH ₃	0.77	Standard	O-rings / lubrication
Argon	Ar	1.78	Standard	
Biogas			Special	Special measuring element
Butane	C ₄ H ₁₀	2.70	Standard	
Carbon dioxide	CO ₂	1.98	Standard	Exception: food industry
Carbon monoxide	CO	1.25	Standard	
Ethane	C ₂ H ₆	1.36	Standard	
Ethylene (gaseous)	C ₂ H ₄	1.26	Standard	Special design
Freon (gaseous)	CCl ₂ F ₂	5.66	Standard	O-rings / lubrication
Helium	He	0.18	Standard	Reduced measuring range
Hydrogen	H ₂	0.09	Special	Reduced measuring range
Hydrogen sulphide (0.2%)	H ₂ S	1.54	Special	Special measuring element
Methane	CH ₄	0.72	Standard	
Natural gas		0.8	Standard	
Nitrogen	N ₂	1.25	Standard	
Oxygen (100%)	O ₂	1.43	Standard	Special design
Pentane	C ₅ H ₁₂	3.46	Standard	
Propane	C ₃ H ₈	2.02	Standard	
Propylene (gaseous)	C ₃ H ₆	1.92	Standard	Special measuring element
Sulphur dioxide	SO ₂	2.93	Special	Special design
Town gas			Standard	

Safety Instructions

The TRZ 03, TRZ 03-L and TRZ 03-K turbine meters are used for measuring the volume at measurement conditions of non-aggressive gases and fuel gases. Measurements of aggressive gases are only permitted if the special designs are used which have been developed for this purpose. These gas meters are not suitable for measuring liquids, otherwise they will be destroyed.

The TRZ 03, TRZ 03-L and TRZ 03-K turbine meters comply with currently applicable standards and regulations. However, failure to operate them properly may cause hazards.

Persons who install or operate the TRZ 03, TRZ 03-L or TRZ 03-K turbine meters in areas subject to explosion hazards, must be familiar with the currently applicable standards and regulations with regard to explosion protection.

The TRZ 03, TRZ 03-L and TRZ 03-K turbine meters have been approved for use in areas subject to explosion hazards and their code is:

EEx ib IIC T6

The appropriate German certificate of conformity for the LF and HF sensors can be found in the annex.

Please observe the following signs:



Danger of explosion

In the manual, this symbol warns you of an explosion hazard. Please observe the instructions given next to this symbol. As to the danger of explosion, please observe the following in particular:

- Connect the pulse outputs of the turbine meter only to intrinsically safe circuits.



Damage to property

In the manual, this symbol warns you of possible damage to property. The instructions given next to this symbol inform you about what you can do to avoid damage to the turbine meter.

No warranty claims can be asserted if there is unauthorized interference with the device!

Installation and Commissioning

Installation

Caution: Please read these installation instructions through and make sure that you have understood the procedure before you start to install the RMG turbine meter or put it into operation.

Turbine meters are precise measuring instruments and must be handled carefully during transport, storage and operation.

When you install the turbine meter, please observe the direction of flow indicated by an arrow on the meter case.



Installation errors may cause physical injuries or result in the destruction of the turbine meter.

It is essential to follow the instructions below:

- Remove the yellow protective film at the flanges **completely**. Rests of this plastic film affect the flow profile and cause measuring errors!
- The RMG TRZ 03, TRZ 03-L and TRZ 03-K turbine meters can be operated in any position up to the nominal diameter of DN 200. From the nominal diameter of DN 250, however, only a horizontal direction of flow is possible. If a particular position was indicated when ordering the turbine meter, you must install the turbine meter in this position. In addition, you must make sure that the filling opening of the lubricator faces upwards.
- Any components affecting the gas flow must be avoided directly upstream of the turbine meter (see DVGW Guideline G 492 II¹⁾ and PTB Guideline G 13²⁾, exception: TRZ 03-L).
- An inlet pipe of a minimum of 2 x DN is required upstream of the **RMG TRZ 03 turbine meter**. The inlet pipe must be designed as a straight pipe section of the same nominal diameter as the gas meter. If there is a heavy flow disturbance, it is necessary to use flow straighteners (see table on next page). A pipe or fitting (bend) of the same nominal diameter as the gas meter and an overall length of 2 x DN must be installed downstream of the gas meter. Temperature measuring instruments may only be installed at a distance of 1 x DN or in the case of nominal diameters of \geq DN 300 at a minimum distance of 300 mm. If there are flow disturbances (e.g. due to a gas pressure regulator) upstream of the inlet pipe, it is also necessary to use a perforated-plate straightener. You can use perforated-plate straighteners complying with ISO 5167-1 or of type RMG LP-35, the latter resulting in a pressure loss which is 2.5 times lower than that of the standardized flow straightener.

¹⁾ can be ordered at DVGW, Josef-Wirmer-Str. 1-3, D-53123 Bonn (www.dvgw.de)

²⁾ can be ordered at PTB, Bundesallee 100, D-38116 Braunschweig (www.ptb.de)

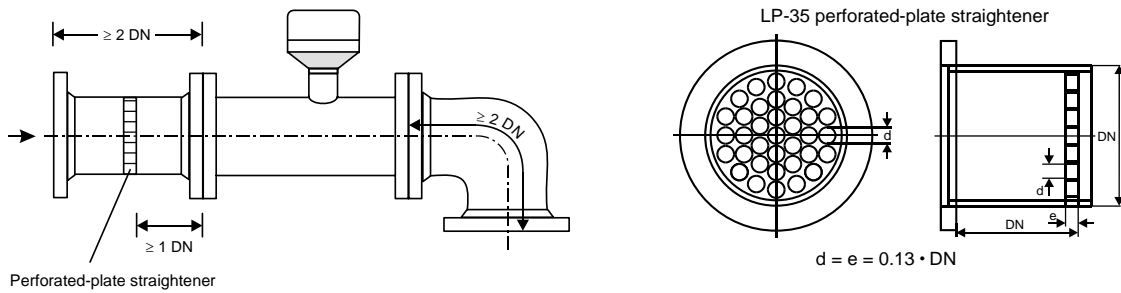

- Upstream of the **RMG TRZ 03-L turbine meter**, no inlet pipe is required, even in the case of heavy flow disturbances such as those caused by a gas pressure regulator. It has been tested without an inlet pipe in compliance with Technical Guideline G13 (which corresponds to the OIML Guideline IR-32/89). A pipe or fitting (bend) of the same nominal diameter as the gas meter and an overall length of 2 x DN must be installed downstream of the gas meter. Temperature measuring instruments may only be installed at a distance of 1 x DN or in the case of nominal diameters of \geq DN 300 at a minimum distance of 300 mm.

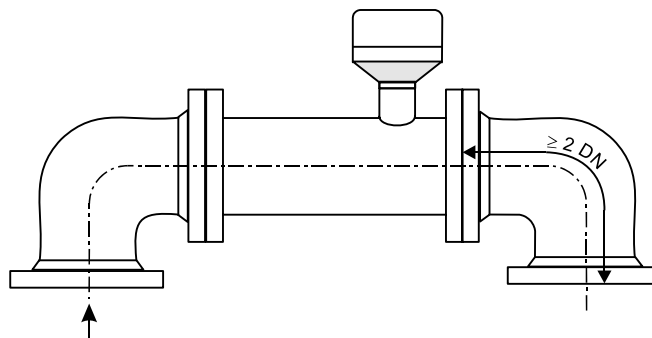

- The opening angle of reducers or expansion fittings installed upstream of a turbine meter of type TRZ 03, TRZ 03-L or TRZ 03-K must not exceed 30°.
- In order to obtain precise measurement results, the turbine meter must be installed in the gas line in such a way that no seals protrude from the flanges into the pipeline.
- A protective screen should be installed on the intake side of the gas meter to protect the turbine meter against any foreign particles possibly contained in the gas flow. The protective screen can be a perforated plate of sheet metal with a hole diameter of 3 mm which is available from RMG.
- The p_r tap which is located on the RMG turbine meter is the pressure-measuring point which was used for taking the relevant pressure at measurement conditions during meter proving. This pressure-measuring point is used for connecting pressure-measuring instruments such as flow computers or volume correctors. Other connection options (e.g. for temperature measurement) can be supplied on a pipe section on the output side of the gas meter.



- **Caution: Protect the turbine meter from damage caused by heavy flow variations, e.g. if the downstream pipeline system must be filled or blown off.**



- **Caution: If it is necessary to do welding work on the gas line, such work can only be performed at a safe distance from the gas meter.** Extreme temperatures prevailing in the gas line in the proximity of the gas meter can result in a permanent damage to the gas meter.



- **Caution: All electrical connections between the gas meter and the amplifiers or the flow computer must be carried out in compliance with the installation instructions.** Make sure that these connections are intrinsically safe.



- **Caution: Any liquids remaining in the gas line after hydrostatic testing can damage the interior parts of the gas meter.** If hydrostatic testing is necessary, the turbine meter must be replaced by a pipe section. Make sure that no liquid remains in the gas line upstream of the gas meter after hydrostatic testing.

- **Operating data**

Recommended threshold values for maximum service life and maximum accuracy:

Maximum overload :	< 20% above Q_{max} , for a short time (< 30 sec)
Maximum flow changes or shock loads	< $0.01 \cdot Q_{max}/sec \hat{=} 1\%$ of Q_{max}/sec e.g. starting up 0 to 100%: > 100 sec
Maximum pressure change :	< 0.1 bar/sec
Maximum flow pulsation :	< 5%
Particle size in the gas flow:	< 5 μm
Lubrication of bearings :	See chapter on "Lubrication". Lubrication intervals depend on the condition of the gas (condensate, rust or dust).
Vibration / mechanical shock:	< 1 mm/sec (vibration velocity)

These specified data must be determined and checked during commissioning, prior to filling and during the start-up and running-in phases of the gas meters. If more than one threshold value occurs at the same time, appropriate action must be taken in the station to improve the measuring conditions.

The operator must **record** all measuring data (gas meter and operating data) during the whole period of operation in order to detect the causes of a possible destruction of the gas meter at an early stage and take corrective action in good time.

Corrective action or reduction of the critical operating conditions can be achieved by the following measures for example:

- Start-up screens (mesh width < 0.15 mm)
- Filters
- Perforated plates (Ø 3 to 4 mm) protecting the gas meter
- Valves with control drive mechanism (flow variation)
- Non-return valves (pulsation and return flow)

• **Technical Guideline G 13**

The installation conditions for new stations complying with TRG G 13 and the simpler installation conditions for RMG turbine meters are compared in the table below.

Type of flow disturbance	Installation cond. as per TR G13	Installation cond. for RMG gas meters Type TRZ 03	Comments
None	Inlet pipe ≥ 5 DN Outlet pipe ≥ 2 DN	Inlet pipe ≥ 2 DN Outlet pipe ≥ 2 DN	The outlet pipe can also be designed as a bend.
	Inlet pipe ≥ 10 DN		Flow disturbances upstream of this inlet pipe need not be considered, if the requirement for an alternating and pulsating flow is fulfilled.
Bend	Inlet pipe ≥ 5 DN	Inlet pipe ≥ 2 DN	
Space bend	Inlet pipe ≥ 5 DN and additionally 2 perforated-plate straighteners or one tube-bundle straightener	Inlet pipe ≥ 2 DN	
Gas pressure regulator with sound attenuator	Inlet pipe ≥ 5 DN	Inlet pipe ≥ 2 DN and additionally one perforated-plate straightener	
Gas pressure regulator without sound attenuator	Inlet pipe ≥ 5 DN and additionally two perforated-plate straighteners	Inlet pipe ≥ 2 DN and additionally one perforated-plate straightener	
Diffuser	Inlet pipe ≥ 5 DN and additionally one perforated-plate straightener	Inlet pipe ≥ 2 DN	
Diffuser with swirling flow	Inlet pipe ≥ 5 DN and additionally two perforated-plate straighteners	Inlet pipe ≥ 2 DN	

Perforated-plate straighteners

There are the following options for flow straighteners:

RMG L1 to L3 perforated-plate straighteners
complying with ISO 5167-1 and DIN 1952

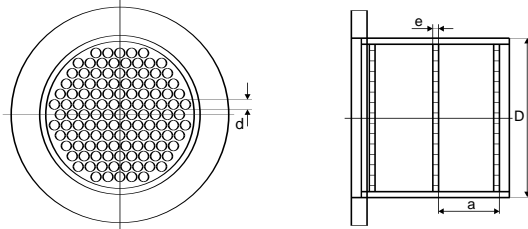

RMG LP-35 perforated-plate straightener

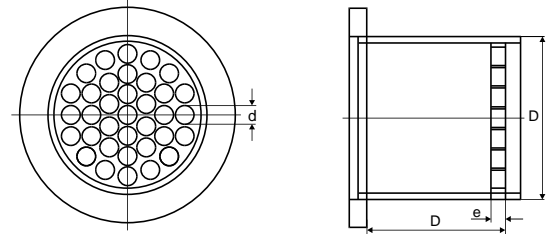

Features	ISO / DIN	L1 to L3	RMG LP-35
Hole diameter d	$d \leq 0.05 D$	$0.04 D$	$0.13 D$
Plate thickness e	$e \geq d$	$e = d$	$0.13 D$
Plate clearance a	$0.5 D \leq a \leq 1 D$	$0.5 D$	-
Opening ratio m	$0.2 \leq m \leq 0.4$	0.3	0.6
Pressure loss, dyn. Δp		$5 - 15 (c^2 \rho / 2)$	$2 - 15 (c^2 \rho / 2)$

In conjunction with RMG turbine meters, these flow straighteners fulfil the requirements of Technical Guideline G 13 and are approved under EU approval No. D 81 / 7.211.10 for turbine meters.

Seals

It must be guaranteed that flange seals of RMG turbine meters do not protrude from the flange into the gas line.

All seals approved as per DVGW can be used depending on the requirements for stability and reliability, e.g.

- grooved seals
- spiral seals
- gaskets.

For recommended dimensions, see the table below.

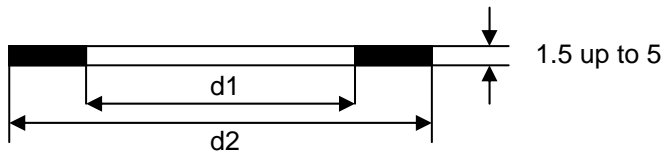

		PN 10	PN 16	PN 25	PN 40
DN	d1	d2			
50	76	107	107	107	107
80	100	142	142	142	142
100	125	162	162	168	168
150	178	218	218	225	225
200	223	273	273	285	292
250	278	328	330	342	353
300	334	378	385	402	418
400	412	490	497	515	547
500	506	595	618	625	628
600	600	695	735	730	745

			ANSI 125	ANSI 150	ANSI 300	ANSI 400	ANSI 600
DN		d1	d2				
50	2"	62	105	105	111	111	111
80	3"	100	136	136	149	149	149
100	4"	125	175	175	181	178	194
150	6"	178	222	222	251	248	267
200	8"	223	279	279	308	305	321
250	10"	278	340	340	362	359	400
300	12"	334	410	410	422	419	457
400	16"	412	515	515	540	537	565
500	20"	506	605	605	655	648	685
600	24"	600	715	715	775	768	790

Screws and nuts

Hexagon head screws: complying with DIN EN 24014

Nuts: complying with DIN EN 24032 or DIN EN 28673

NOTE! Pursuant to AD Notice W7, you should use these screws and nuts only up to a maximum of M30 and a maximum of 40 bar!

In metric flanges: Screw bolts complying with DIN 2509 and DIN 2510-1

In flanges complying with ANSI/ASME B16.5-1988: Use screw bolts with continuous threads complying with ANSI/ASME B.1.1:1989.

Material complying with W7 or material complying with ASTM A194 2H.

Selection of **stud bolts and nuts**

Pressure	Temperature (°C)	Material	
		Stud bolt	Nut
Up to 100 bar	0 to 480	A 193 B6	A 194 Gr. 6
	-50 to 450	A 193 B7	A 194 Gr. 2H

Selection of **screws and nuts**

Nominal pressure	Permissible fluid temperature	Material Strength class		Standard	
		Screw	Nut	Screw	Nut
Up to 40 bar	-10 to 300	5.6	5	DIN 931 DIN 976	DIN 934
Up to 100 bar	-10 to 400	CK 35	CK 35	DIN 976 DIN 2510	DIN 934 DIN 2510

Types of totalizers

The RMG turbine meter can be fitted with different totalizers.



Type "A" meter head



Type "D" meter head



Type "F" meter head

Type "F" meter head

The new standard design is type "F" meter head without mechanical drive shaft couplings. Therefore, this design provides no options for connecting additional mechanical equipment. The totalizer has the following features:

- LF pulse transmitter
 - Standard: reed contact
 - Alternatively: inductive pulse transmitter
 - Option: up to two additional inductive LF pulse transmitters
- HF pulse transmitters are optionally available, pulse frequency approx. 100 Hz at Q_{max}
- IP 65 protection class
- Universally readable
- Totalizer unit and HF 1 pulse transmitter are easily replaceable on site.

**The electrical connector must be covered by a cap closure or a connecting plug!
Otherwise moisture may ingress into the meter head.**

Type "F-D" meter head

Design and features like in the case of the type "F" meter head but additional with a mechanical drive shaft in compliance with EN 12261 on the top side of the case.

The direction of rotation of the drive shaft (with view on the drive shaft) is clockwise.

For dimensions and instructions for the connection see the description of the type "D" meter head. Especially note the maximum permissible torques!



Permissible torques (type “F-D”)

Nominal dia. DN	Sizes G	Q _{max} m ³ /h	Q _{min} [m ³ /h]			M _{max} [Nmm]		
			1:20	1:10	1:5	1:20	1:10	1:5
50	40	65	-	-	13	-	-	-
50	65	100	-	10	20	-	-	-
80	100	160	8	16	32	-	1,0	2,0
80	160	250	13	25	50	1,4	2,4	3,9
80	250	400	20	40	80	1,4	2,3	3,9
100	160	250	13	25	50	0,14	0,6	1,3
100	250	400	20	40	80	0,5	1,1	2,1
100	400	650	32	65	130	0,8	1,6	3,3
150	400	650	32	65	130	0,5	1,5	2,4
150	650	1000	50	100	200	1,3	2	3,3
150	1000	1600	80	160	320	11,5	15,7	37,3
200	1000	1600	80	160	320	11	15	37
200	1600	2500	130	250	500	11	15	37
250	1000	1600	80	160	320	11	15	37
250	1600	2500	130	250	500	11	15	37
250	2500	4000	200	400	800	11	15	37
300	2500	4000	200	400	800	11	15	37
300	4000	6500	320	650	1300	11	15	37
400	4000	6500	320	650	1300	11	15	37
400	6500	10000	500	1000	2000	11	15	37
500	6500	10000	500	1000	2000	11	15	37
500	10000	16000	800	1600	3200	11	15	37
600	16000	25000	1300	2600	5000	11	15	37

Type “A” meter head

The old standard design is type “A” meter head without mechanical drive shaft couplings. This design provides no options for connecting additional mechanical equipment.

The totalizer has the following features:

- LF pulse transmitter
 - Standard: reed contact
 - Alternatively: inductive pulse transmitter
- HF pulse transmitter is optionally available, pulse frequency approx. 100 Hz at Q_{max}

Type “D” meter head

Type “D” meter head provides two mechanical drive shafts where additional equipment, e.g. slip-on pulse transmitters, volume correctors, etc., can be attached under official supervision. Before you connect additional mechanically driven equipment, you must make sure that the direction of rotation and the rotation rate U_a (see “Specifications” of the gas meter) comply with the data on the gas meter. The torque required for driving the additional equipment must not exceed the value stated on the indicating plate of the drive shaft.

Do not use the protruding totalizer of type “D” meter head as a handle to carry the gas meter during transport.

The totalizer has the following features:

- LF pulse transmitter
 - Standard: reed contact
 - Alternatively: inductive pulse transmitter
 - Option: one additional inductive pulse transmitter
- HF pulse transmitters are optionally available, pulse frequency approx. 100 Hz at Q_{max}
- Additional mechanical equipment can be connected.

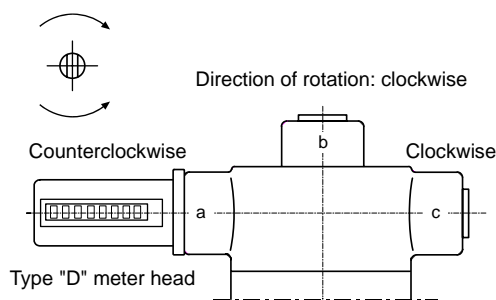

Direction of rotation of the drive shafts

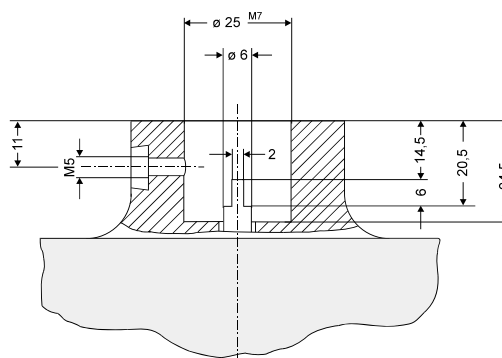

Dimensions of the drive shaft coupling

Connection of additional equipment

The drive shaft couplings of the meter head (type “D”) can be used for connecting additional mechanical or electronic measuring instruments. In this case, the total driving torque must not exceed the approved value. If no additional equipment is used, the drive shaft couplings are sealed.

The rotation rates of the drive shaft coupling depend on the meter size (see table).

NOTE!

Additional equipment or additional measuring instruments can only be attached or removed under official supervision. Before you connect additional equipment, make sure that the direction of rotation and the rotation rate of mechanical transmission coincide. Depending on the location for attaching additional equipment, you can turn the meter head into the most favourable position for installation without damaging the locking seals by loosening two hexagon socket screws.

Permissible torques (type “D”)

Due to the fact that the measuring range of turbine meters can be adversely affected by the torque of additional mechanically driven equipment, the permissible maximum torques in Nmm stated in the table below apply in relation to the flow range and the nominal diameter.

Sizes	Nominal dia. DN	Q _{max} m ³ /h	Q _{min} m ³ /h	M _{max} Nmm	P _{max} bar
G 40	50	65	13	--	100
G 65	50	100	10 20	-- --	100
G 100	80	160	16 32	1.0 2.0	100
G 160	80	250	13 25 50	1.4 2.3 3.9	100
G 250	80	400	20 40 80	1.4 2.3 3.9	100
G 160	100	250	13 25 50	-- 0.6 1.6	100
G 250	100	400	20 40 80	0.8 1.4 2.3	100
G 400 G 400 G 400	100	650	32 65 130	0.8 1.4 3.4	100
G 400 G 400 G 400	150	650	32 65 130	0.6 2.0 3.9	100
G 650	150	1000	50 100 200	2.0 4.0 9.8	100
G 1000	150	1600	80 160 320	16 38 90	100
G 1000	200	1600	80 160 320	16 38 90	100
G 1000	250	1600	80 160 320	12 20 36	100
≥ G 1600	200	2500	0.05 Q _{max} 0.1 Q _{max} 0.2 Q _{max}	16 39 98	100

General

After you have loosened the two locking screws located on both sides of the meter head, you can turn all meter head designs (types A, D and F) through 350° to reach an optimum position for taking meter readings. To do this, you need an SW 2 hexagon socket wrench.

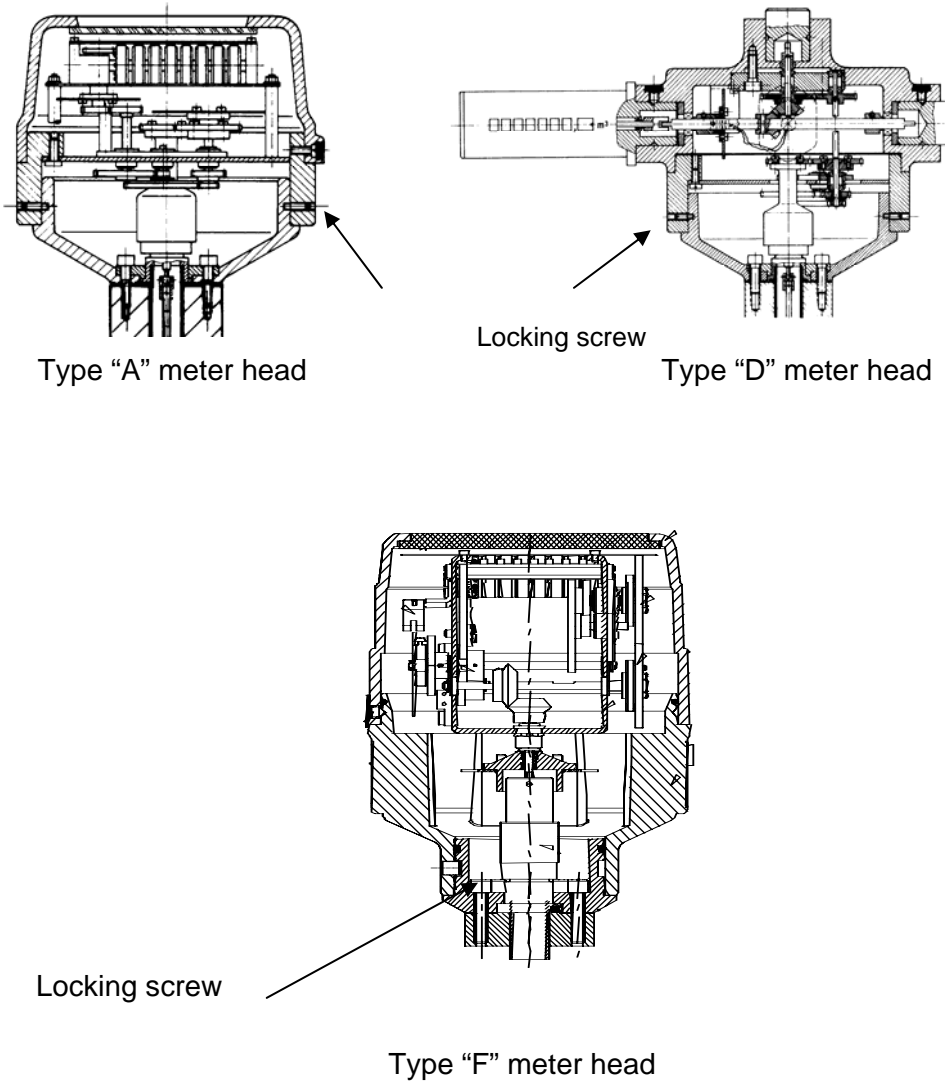

If work has to be done on the meter head, please make sure that the official seals are not damaged.

Pulse transmitters

The TRZ 03, TRZ 03L and TRZ 03-K turbine meters provide different sensors which supply volume pulses in a variety of frequency ranges. These pulses can be further processed by volume correctors or remote totalizers, for example. All pulse transmitters of the TRZ 03 and TRZ 03L have been approved for custody transfer metering. The connection options are shown in the following illustration.

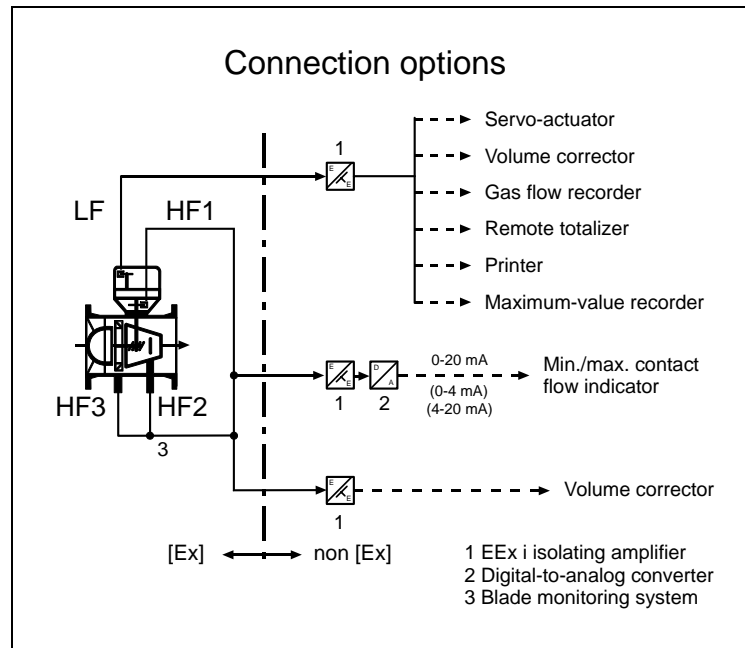

All pulse transmitters are intrinsically safe and must be connected only to intrinsically safe circuits if they are used in areas subject to explosion hazards. The safety barriers must meet the requirements of the **EEx ib IIC** type of protection.

Pulse transmitters in the meter head (LF and HF 1)

The meter heads of the RMG TRZ 03, TRZ 03K and TRZ 03L turbine meters are fitted with a reed contact as standard. The pulse value corresponds to the rotation rate U_a . See the indicating plate on the meter head for exact frequency data. The guide values are given in the tables on pages 34 through 36. The maximum pulse frequency is 0.3 Hz. Optionally, a slot-type initiator can be installed.

In applications where a higher resolution is required, an additional HF 1 pulse transmitter can be installed. Then the maximum pulse frequency will be of the order of approx. 300 Hz at Q_{max} . The connector pin assignments for the standard design with a reed contact (alternatively, with a slot-type initiator) are shown in the illustration below. Please also note the indicating plate on the meter head.

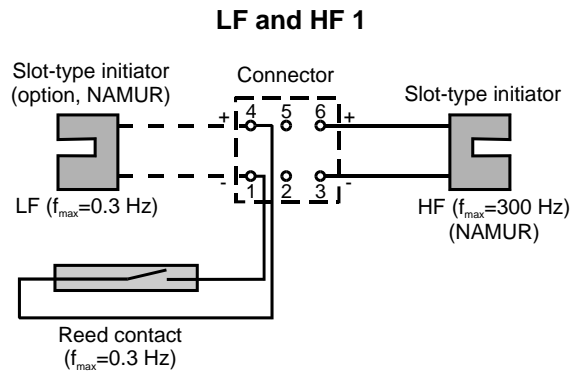

Pulse transmitters in the measuring element (HF 2 and HF 3)

The higher-frequency flow signals from the HF 2 and HF 3 proximity sensors are used for control purposes and in conjunction with electronic flow computers suitable for custody transfer metering. In the case of the HF 3 pulse transmitter, the pulses are picked off at the turbine wheel, while they are picked off at the reference wheel for the HF 2 pulse transmitter. The two wheels are arranged in such a way that two pulse series of the same frequency are generated which are out of phase by 180° . The exact frequency is determined during meter proving and is stated on a supplementary data plate on the meter case. The guide values are listed in the tables on pages 34 through 36. The maximum pulse frequency is approx. 2100 Hz at Q_{max} , but depends on the meter size.

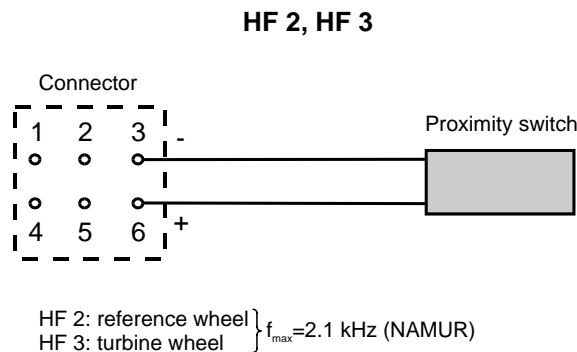

Connections are made by means of multi-pin connectors.

Normally, an LF pulse transmitter is connected to contacts 1 and 4, while a single HF 1 pulse transmitter is connected to contacts 3 and 6. Here the highest number is always (+).

High-frequency pulse transmitters which go with the turbine wheel (HF 2) or the reference wheel (HF 3) are usually connected to contacts 3 and 6. Here the highest number is always (+).

Connector pin assignments

Connector, 7 pins
(produced by Binder)

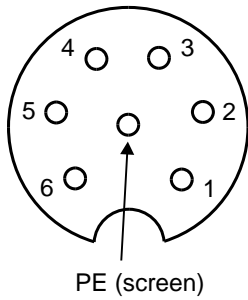

- 1 -
- 4 + LF signal reed or Namur
- 2 -
- 5 + optionally, LF or HF signal
- 3 -
- 6 + HF signal Namur

Connector, 4 pins
(produced by Hirschmann)

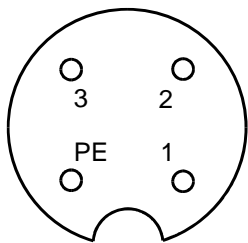

- 1 -
- 2 + LF signal reed or Namur

Connector, 6 pins
(produced by Harting)

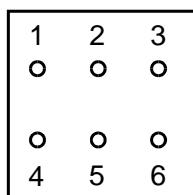

- 1 -
- 4 + LF signal reed or Namur
- 2 -
- 5 + optionally, LF or HF signal
- 3 -
- 6 + HF signal Namur

Here the cable connector is depicted.
(Connecting part is provided by the customer.)

Specifications of the pulse transmitters

Electrical data:

Reed contact

Contact as make-contact element

Max. contact load	10 watt
Max. switching voltage	200 VDC
Max. switching current	0.5 A
f_{\max}	0.3 Hz

LF slot-type initiator

Inductive proximity switch complying with DIN 19234 (NAMUR)

Supply voltage	7 to 9 VDC (with internal resistance $R_i = 1 \text{ k}\Omega$)
Current if switch is not operated	$\geq 3 \text{ mA}$
Current if switch is operated	$\leq 1 \text{ mA}$
f_{\max}	0.3 Hz

HF 1 slot-type initiator

Inductive proximity switch complying with DIN 19234 (NAMUR)

Supply voltage	7 to 9 VDC (with internal resistance $R_i = 1 \text{ k}\Omega$)
Current if switch is not operated	$\geq 3 \text{ mA}$
Current if switch is operated	$\leq 1 \text{ mA}$
f_{\max}	300 Hz

HF 2 slot-type initiator

Inductive proximity switch complying with DIN 19234 (NAMUR)

Supply voltage	7 to 9 VDC (with internal resistance $R_i = 1 \text{ k}\Omega$)
Current if switch is not operated	$\geq 3 \text{ mA}$
Current if switch is operated	$\leq 1 \text{ mA}$
f_{\max}	2100 Hz

Temperature measurement

In order to measure the gas temperature, a resistance thermometer can be used in a thermowell in a fitting downstream of the gas meter. It is recommended that a second thermowell, e.g. for a monitoring thermometer, be used. If such thermowells are not provided for in the meter case, temperature measurement must be performed at a distance of up to 3 x DN or a maximum of 600 mm downstream of the turbine meter.

All turbine meters of types TRZ 03 and TRZ 03-L from the nominal diameter of DN 80 (3") upwards can be fitted with a thermowell for a PT100 resistance thermometer. Due to their short size, turbine meters of type TRZ 03-K cannot be fitted with a thermowell.

Operating temperatures prevailing at outdoor metering stations in winter or at natural gas metering stations downstream of regulating stations are usually in the range of -5°C to +10°C. By comparison, higher operating temperatures prevail at metering stations located downstream of compressor stations. For this reason, the measuring elements of the temperature sensors located outside the gas line must be appropriately insulated against the weather. In order to achieve optimum thermal conduction, oil as a heat transfer liquid should be filled in the thermowells in any case.

Commissioning

Filling with oil

When the turbine meters are delivered, the lubricators do not contain any oil. The oil pumps must not be filled with oil until they are at the installation site prior to commissioning! A small bottle of oil is supplied with each gas meter. Then you have to perform an initial lubrication. For this see the detailed lubrication instructions in chapter "Lubrication" from page 29.

Connecting the gas flow



Do not fill any downstream pipelines or station sections through the turbine meter. This may speed up the turbine wheel and lead to excessively high loads with resultant damage.

Short-time overload operation of 20% above the maximum flow rate Q_{\max} is permissible. Such load conditions should be avoided, however, since in most cases they cannot be controlled and exceed the officially approved limits for custody transfer metering. Moreover, such overloads reduce the service life of the gas meter.

The gas flow must be free of foreign particles, dust or liquids. Otherwise it is recommended that filters or separators be installed.

Operation

Influences on the error of measurement due to operation

Intermittent operation

Rapid changes of the gas flow should be avoided, since the turbine wheel can follow these changes only with a certain delay due to its inertia. In this way, errors of measurement occur, in particular, if the gas flow is shut off. Since in this case the turbine wheel slows down after the flow has stopped, a gas volume is measured which is always higher than that which has actually flowed through the gas meter.

In the supplement to PTB Guideline G 13, an instrument is stipulated which records the flow during the slow-down time of the turbine wheel for intermittent operation (i.e. if the gas flow is permanently switched on and shut off). If control signals of a shut-off valve are available, this volume can be recorded for **custody transfer metering purposes** for example by the TAZ 9, an RMG device recording the gas volume during the slow-down time of turbine meters after flow stop (for custody transfer metering only in conjunction with the TRZ 03 or TRZ 03-L). As soon as the shut-off valve is closed, the TAZ 9 starts to record the gas volume during the slow-down time of the turbine meter.

Influence of pulsations

The gas flow must be free of shocks or pulsations. A gas metering station can be affected by flow pulsations, however, if the following equipment has been installed upstream or downstream in the system:

- reciprocating piston compressors,
- rotary displacement meters,
- gas pressure regulators lacking steadiness of operation,
- pipes where no gas flows (siphons).

Volume flow pulsation is the decisive quantity for evaluating the performance of gas meters under the influence of pulsations. Volume flow pulsation is physically always associated with **pressure variations**.

The following relation is established in a first approximation:

$$\hat{Q}_{\text{rel}} \approx \hat{p}_{\text{rel}} \cdot \frac{DN^2}{\bar{Q}} \cdot K$$

where:

\hat{Q}_{rel} : is the relative volume flow pulsation (peak-to-peak)

\bar{Q} : is the mean volumetric flow

\hat{p}_{rel} : is the relative pressure pulsation (peak-to-peak)

DN: is the nominal diameter of the gas meter

K: is a constant depending on standard density, velocity of sound, compressibility, pressure at base conditions, temperature, and station-specific parameters.

With this relation, it is possible to estimate volume flow pulsation on the basis of pressure pulsation, which can be measured more easily.

Direct measurement of volume flow pulsation is preferable, however, since the results are more reliable.

The crucial factor is the pulsation **at the location of measurement**.

Consequences

In the case of pulsating flow, the turbine meter shows a measured value which is too high.

Due to the pulse applied by the flow on the impeller which increases quadratically with the flow velocity, the resultant rotational speed is higher than the mean value of the flow velocity. The influence with high gas density is less, but increases with a high mass moment of inertia (heavy impeller) or fast-running wheels.

Furthermore, high pulsation amplitudes may result in premature wear of shaft bearings due to increased load.

Limiting values

Frequency ranges

- It is generally unlikely that measured values will be distorted in the frequency range above 100 Hz.
In practice, it is hardly possible to initiate any significant flow variations at such frequencies.
- Disturbances are to be expected most frequently in the frequency range between 0.1 Hz and 100 Hz, since with typical station dimensions, the gas column can be expected to produce resonances. Flow variations with a high relative amplitude may occur.
- In the frequency range below 0.1 Hz, there is a quasi-steady flow which will not cause any distortion with the gas meters.

Pulsation amplitudes

Studies have shown that no disturbances are to be expected in the case of relative **flow pulsations below 5% (peak-to-peak)** and relative **pressure pulsations of less than 0.1% to 0.5% (peak-to-peak)**.

These data should be regarded as approximate values depending on the flow rate and pulsation frequency involved.

Lubrication

Lubricator

For lubrication, either an oil gun or a permanently fitted oil pressure pump is used. The various designs are given in the tables below.

	Type of oil pump	Container volume	Delivered quantity
DO	Oil gun (oil nipple)	150 cm ³	0,6 cm ³ /stroke
KO	Pushbutton pump	8 cm ³	0,114 cm ³ /stroke
GO	Lever pump	150 cm ³	1,5 cm ³ /stroke
DO	Permanent lubrication	--	--

	TRZ 03-K		TRZ 03 and TRZ 03L	
	Pressure classes		Pressure classes	
DN	PN 10, 16 ANSI 150	PN 25, 40, 64, 100 ANSI 300, 600	PN 10, 16 ANSI 150	PN 25, 40, 64, 100 ANSI 300, 600
50	DS (KO) ¹⁾	KO	DS (KO) ¹⁾	KO
80	DS (KO) ¹⁾	KO	DS (KO) ¹⁾	KO
100	DS (KO) ¹⁾	KO	DS (KO)	KO
150	DS (KO) ¹⁾	KO	DS (KO)	KO
200	KO		KO	
250	KO	GO	GO	
300	GO		GO	
400	GO		GO	
500	GO		GO	
600	GO		GO	

1) meters manufactured before November 2007 with DO

Types in brackets are options

Specification for lubricating oils

For lubrication purposes, we recommend that you use only Shell Morlina Oil 10 or another lubricating oil with 2 to 4°E at 25°C complying with MIL-L-6085-A in order to avoid damage to the shaft bearings. You can order your supply of lubricating oil from us in 1-liter containers under Ref. No. 82.11.142.00.

Shelf life of oil: the shelf life depends on the operating conditions (e.g. UV light, humidity etc.). In principle the oil suffers no quality loss during the first 3-4 years.

Initial lubrication

When the turbine meters are delivered, the lubricators do not contain any oil. The oil pumps must not be filled with oil until they are at the installation site prior to commissioning. A small bottle of oil is supplied with each gas meter.

For the initial lubrication more pump strokes are necessary than for the relubrications because first the oil pipes have to be filled with oil.

Pump	DN 50 – DN 200	DN 250 – DN 600
DO (oil gun)	20 strokes ^{*)}	-
KO (pushbutton pump)	40 strokes	45 strokes
GO (lever pump)	-	10 strokes

^{*)} after venting the oil gun!

Relubrication

The relubrication intervals are stated on a red indicating plate on the meter case. See also "Lubrication procedure".

Example:

Relubrication!
Every 3 months 2 strokes
Lubricating oil: 2-4°E at 25°C
conforming to MIL-L-6085-A
see operating instructions

In the case of unfavourable operating conditions, such as condensate forming because of water or hydrocarbon, or dust-laden gas, or service temperatures above 50°C, we recommend that lubrication be performed at shorter intervals, even daily under extreme conditions (permanent formation of condensate).

If the gas meter is operated under the above-mentioned conditions, it is likely that its service life will be reduced. If you have questions to the relubrication in such cases please contact RMG.

Lubrication procedure

To fill the pumps and lubricate the turbine meters, proceed as follows:

Oil gun

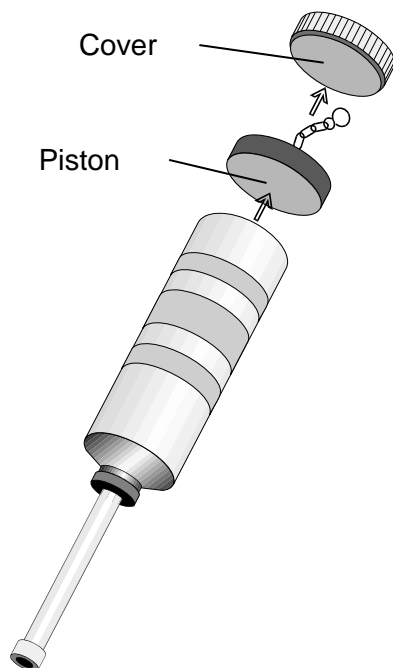

To fill with oil:

1. Unscrew cover.
2. Pull piston by means of the chain.
3. Fill with oil.
4. Reinsert piston by pushing it as far as possible.
5. Screw on cover again tightly.
6. **Vent the oil gun!**

To lubricate:

1. Plug oil gun onto oil nipple.
2. Depress oil gun towards oil nipple once for each stroke.

Every 3 months **2 strokes**

Pushbutton pump

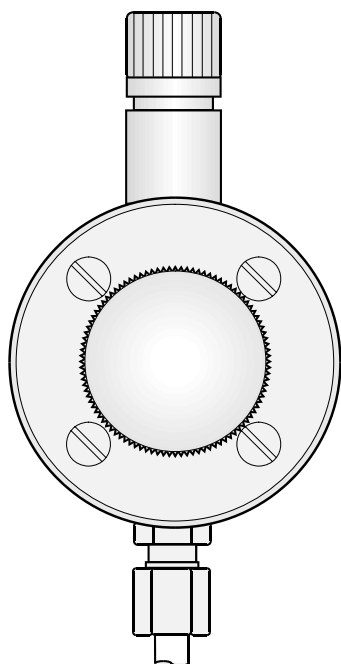

To fill with oil:

1. Unscrew cover.
2. Fill with oil.
3. Screw on cover again.

To lubricate:

1. Unscrew knurled cover (or hexagon cover in the case of older designs).
2. Depress pushbutton, which is now visible, once for each stroke.
3. Screw on knurled (or hexagon) cover again.

Every 3 months **6 strokes**

Lever pump

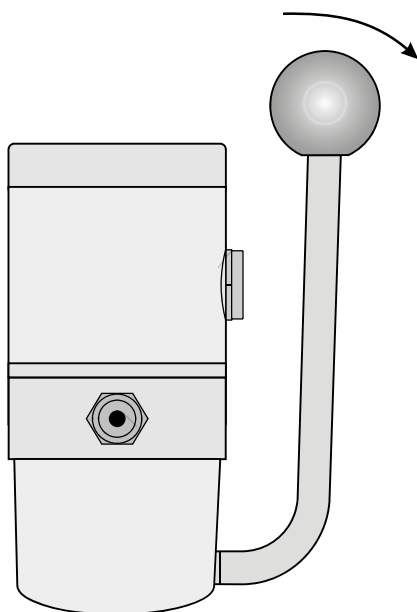

To fill with oil:

1. Pull off cover upwards (in the case of lever pumps with transparent container, unscrew cover).
2. Fill with oil.
3. Screw (or plug) on cover again tightly.

To lubricate:

1. Move lever once for each stroke as far as it will go.

Up to DN 400: every 3 months **2 strokes**
 From DN 500: every 3 months **3 strokes**

Maintenance instructions

RMG turbine meters are maintenance-free except that they require lubrication at regular intervals. Since all gas meters fitted with oil pumps are shipped with an empty oil storage tank, it is absolutely essential to fill the storage tank of the oil pump with oil and perform the initial lubrication before the gas meter is put into service (see section “Lubrication”).

The operator should nevertheless check the turbine meter at regular intervals. In this connection, please refer also to DVGW code of practice G 495¹⁾. (Gas pressure regulators for monitoring and servicing large-scale gas metering systems)

The gas meter should be checked for accuracy approximately every two years depending on whether it is possible or necessary to perform such checks. This can be done as follows:

- In the station itself by connecting two gas meters in series.
- In an officially acknowledged testing laboratory for gas measuring instruments.
- In the factory.

Labelling

All important data which are necessary for operating the gas meter are stated on the plates which are affixed to the meter case, totalizer or pulse transmitters.

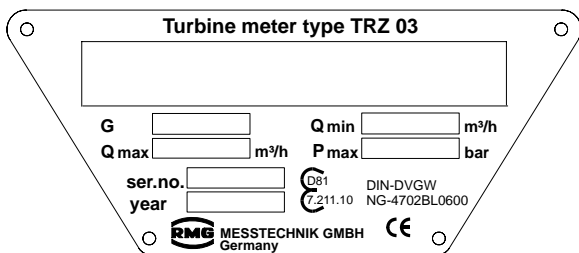

Main data plate of the TRZ 03 turbine meter with type “F” meter head

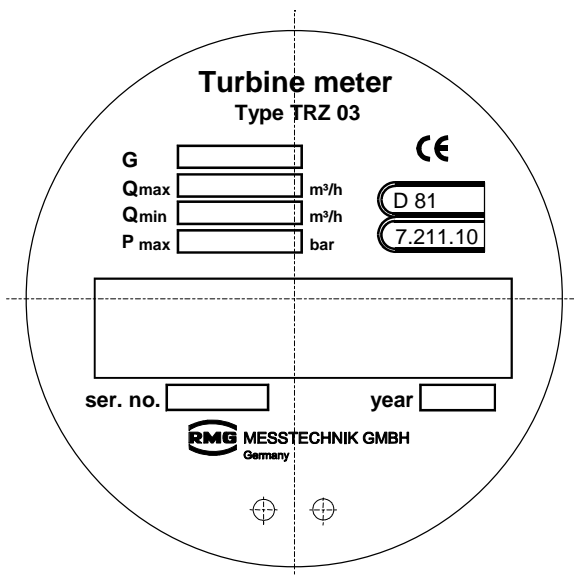

Main data plate of the TRZ 03 turbine meter with type “A” meter head

¹⁾ can be ordered at DVGW, Josef-Wirmer-Str. 1-3, D-53123 Bonn (www.dvgw.de)

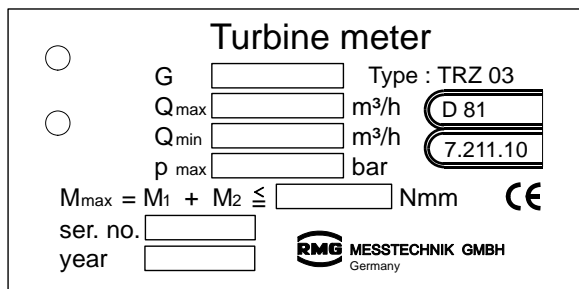

Main data plate of the TRZ 03 turbine meter with type "D" meter head

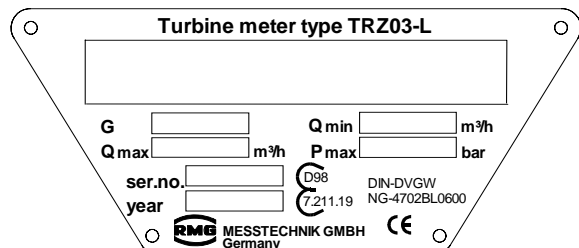

Main data plate of the TRZ 03-L turbine meter with type "F" meter head

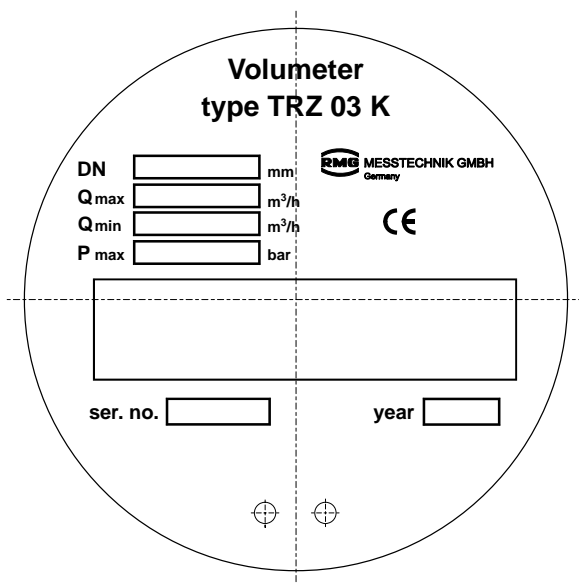

Main data plate of the volumeter with type "A" meter head

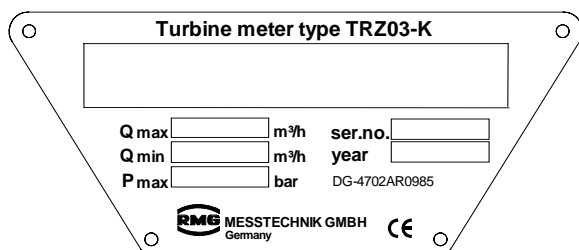

Main data plate of the volumeter with type "F" meter head

Pulse Outputs
 For use only with intrinsically safe and approved equipment



I1	1••4	1m ³ ≅	<input type="text"/>	imp NF-Reed
I2	2••5	1m ³ ≅	<input type="text"/>	
I3	3••6	1m ³ ≅	<input type="text"/>	imp HF1-Namur

Built-in pulse transmitters, type "A", "D" and "F" meter heads

Re - Lubrication
 At 3 month intervals, 2 strokes.
 Lubricant: 2-4°E at 25°C
 corresponding to MIL-L-6085-A.
 Supplementary information see operating instructions.

Indicating plate for relubrication of the main bearings

Re- Lubrication
 At 3 month intervals, 6 strokes.
 Lubricant: 2 - 4°E at 25°C
 conforming to MIL-L-6085-A.
 The containervolume of 0,15 litre is sufficient for 3 months. Supplementary information see operating instructions.

Indicating plate for relubrication of the main bearings



Arrow indicating the direction of flow

p_r

Indication of the reference pressure tap

Specifications

Measuring ranges / Dimensions / Pressure classes of the TRZ 03

DN mm in	Size	Measuring range		U _a m ³	Pressure classes / Approx. weight				Dimensions			
		Q _{min} -Q _{max} m ³ /h			PN	kg	ANSI	kg	L	H	C	
		1:10/1:20	1:30									
50 2"	G 40	13-65*	-	0.1	10/16	13	150	13	150	210	60	
	G 65	10-100	-	0.1	25/40	21	300	13				
					64/100	21	600	21				
80 3"	G 100	16-160	-	1	10/16	20	150	20	240	230	96	
	G 160	13-250	-	1	25/40	25	300	25				
	G 250	20-400	-	1	64/100	34	600	36				
100 4"	G 160	13-250	-	1	10/16	25	150	30	300	240	120	
	G 250	20-400	-	1	25/40	32	300	35				
	G 400	32-650	20-650	1	64/100	45	600	55				
150 6"	G 400	32-650	-	1	10/16	50	150	50	450	265	180	
	G 650	50-1000	32-1000	1	25/40	60	300	65				
	G 1000	80-1600	50-1600	10	64/100	70/90	600	100				
200 8"	G 1000	80-1600	50-1600	10	10/16	75	150	100	600	300	240	
	G 1600	130-2500	80-2500	10	25/40	95	300	120				
					64/100	150/160	600	160				
250 10"	G 1000	80-1600	-	10	10/16	100/110	150	110	750	330	300	
	G 1600	130-2500	80-2500	10	25/40	135/150	300	160				
	G 2500	200-4000	130-4000	10	64/100	180/225	600	260				
300 12"	G 2500	200-4000	130-4000	10	10/16	138/150	150	155	900	360	360	
	G 4000	320-6500	200-6500	10	25/40	225/265	300	230				
					64/100	275/290	600	310				
400 16"	G 4000	320-6500	200-6500	10	10/16	200/290	150	350	1200	400	480	
	G 6500	500-10000	320-10000	10	25/40	350/440	300	460				
					64/100	525/580	600	575				
500 20"	G 6500	500-10000	320-10000	10	10/16	560/610	150	620	1500	450	600	
	G 10000	800-16000	500-16000	100	25/40	640/700	300	650				
					64/100	830/1060	600	1075				
600 24"	G 10000	800-16000	500-16000	100	10/16	900/940	150	950	1800	500	720	
	G 16000	1300-25000	800-25000	100	25/40	980/1075	300	1000				
					64/100	1230/1570	600	1600				

* (Measuring range 1:5)

PN pressure classes complying with DIN 2401, part 1,
ANSI pressure classes complying with B16.5.

From DN 80 to DN 300, the turbine meters of the PN 10/16 pressure class can be fitted with a thermowell to accommodate a resistance thermometer.

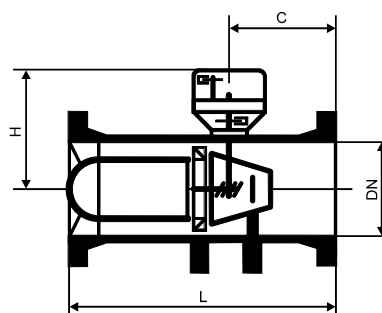

Measuring ranges / Dimensions / Pressure classes of the TRZ 03-L

DN mm in	Size	Measuring range		U _a m ³	DN mm in	Pressure classes / Approx. weight				Dimensions		
		Q _{min} -Q _{max} m ³ /h				PN	kg	ANSI	kg	L	H	C
		1:10/1:20	1:30									
50 2"	G 65	10-100	- -	0.1	50 2"	10/16 25/40 64/100	13 21 21	150 300 600	13 13 21	150	235 235 250	28
80 3"	G 100 G 160	16-160 13-250	- -	1 1	80 3"	10/16 25/40 64/100	20 25 34	150 300 600	20 25 36	240	260 260 270	40
100 4"	G 160 G 250	13-250 20-400	- -	1 1	100 4"	10/16 25/40 64/100	25 32 45	150 300 600	30 35 55	300	270 275 290	50
150 6"	G 400 G 650	32-650 50-1000	- 32-1000	1 1	150 6"	10/16 25/40 64/100	50 60 70/90	150 300 600	50 65 100	450	290 300 325	80
200 8"	G 1000	80-1600	50-1600	10	200 8"	10/16 25/40 64/100	75 95 150/160	150 300 600	100 120 160	600	290 290	120
250 10"	G 1000 G 1600	80-1600 130-2500	- 80-2500	10 10	250 10"	10/16 25/40 64/100	100/110 135/150 180/225	150 300 600	110 160 260	750	330	165
300 12"	G 2500	200-4000	130-4000	10	300 12"	10/16 25/40 64/100	140/155 230/270 280/295	150 300 600	160 235 315	900	360	200
400 16"	G 4000	320- 6500	200-6500	10	400 16"	10/16 25/40 64/100	290/300 360/450 535/590	150 300 600	360 470 585	1200	400	300
500 20"	G 6500	500-10000	320-10000	10	500 20"	10/16 25/40 64/100	575/625 655/715 845/1075	150 300 600	635 665 1090	1500	450	385
600 24"	G 10000	800-16000	500-16000	100	600 24"	10/16 25/40 64/100	925/965 1000/1100 1250/1590	150 300 600	975 1025 1625	1800	500	480

PN pressure classes complying with DIN 2401, part 1,
ANSI pressure classes complying with B16.5.

From DN 80 to DN 300, the turbine meters of the PN 10/16 pressure class can be fitted with a thermowell to accommodate a resistance thermometer.

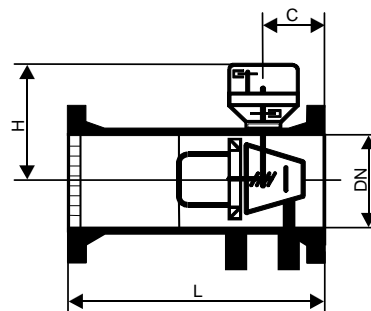

Measuring ranges / Dimensions / Pressure classes of the TRZ 03-K

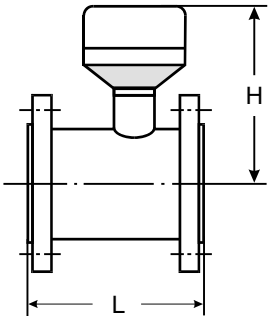
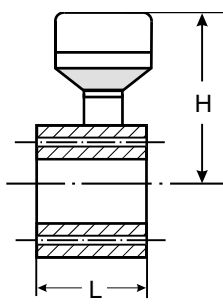
Nominal dia. DN		Measuring range Q_{\min} - Q_{\max} m ³ /h	Ua m ³	Pressure classes	L	H*	Weight app. kg	Case design
mm	in				mm	mm		
50	2"	6-100	0.1	PN 10, 16, 25, 40 ANSI 150, 300	150	212	10	Flanged-end design 
80	3"	13-160 16-250 (25-400)	1	PN 10, 16, 25, 40 ANSI 150	120	245	14	
100	4"	25-400 (40-650)	1	PN 10, 16, 25, 40 ANSI 150	150	255	25	
150	6"	40-650 65-1000 (100-1600)	1	PN 10, 16, 25, 40 ANSI 150	175	285	40	
200	8"	100-1600 160-2500	10	PN 10, 16, 25, 40 ANSI 150	200	305	60	
250	10"	160-2500 (250-4000)	10	PN 10, 16, 25 ANSI 150	300	300	70	
300	12"	250-4000 (400-6500)	10	PN 10, 16, 25 ANSI 150	300	365	100	
				PN 40, 64, 100 ANSI 300, 600	450	415	200	
400	16"	400-6500 (650-10000)	10	PN 10, 16, 25 ANSI 150	600	390	280	
				PN 40, 64, 100 ANSI 300, 600	600	450	400	
500	20"	650-10000 (1000-16000)	10	PN 10, 16, 25 ANSI 150	750	445	500	
				PN 40, 64, 100 ANSI 300, 600	750	515	650	
600	24"	1000-16000 (1600-25000)	100	PN 10, 16, 25 ANSI 150	900	465	650	
				PN 40, 64, 100 ANSI 300, 600	900	580	850	
50	2"	6-100	0.1	PN 64, 100 ANSI 600	80	212	15	Monoflange design 
80	3"	10-160 16-250 (25-400)	1	PN 64, 100 ANSI 300, 600	120	245	35	
100	4"	25-400 (40-650)	1	PN 64, 100 ANSI 300, 600	150	255	50	
150	6"	40-650 65-1000 (100-1600)	1	PN 64, 100 ANSI 300, 600	175	285	100	
200	8"	100-1600 160-2500	10	PN 64, 100 ANSI 300, 600	200	305	130	
250	10"	160-2500 (250-4000)	10	PN 40, 64, 100 ANSI 300, 600	250	300	200	

DN 700 to 1000 on request.

* Dimension "H" with built-in totalizer (with attached totalizer: dimension "H" + 28 mm).

Q_{min} depending on the operating pressure in natural gas

G	Q _{max} m ³ /h	Q _{min,LP} ¹⁾ m ³ /h	Q _{min,LP} – natural gas m ³ /h									
			Operating pressure in bar _a									
			5	10	15	20	30	40	50	60	100	
65	100	10 ²⁾	5	4	3	3	2	2	2	2	2	1
100	160	16 ²⁾	7	6	4	4	3	3	2	2	2	2
160	250	13	7	6	4	4	3	3	2	2	2	2
250	400	20	11	8	6	6	5	4	4	4	3	2
400	650	32	18	13	10	9	7	6	6	6	5	4
650	1000	50	28	20	16	14	11	10	9	9	8	6
1000	1600	80	44	31	26	22	18	16	14	14	13	10
1600	2500	130	72	51	42	36	29	26	23	23	21	16
2500	4000	200	111	78	64	55	45	39	35	35	32	25
4000	6500	320	178	126	103	89	72	63	56	56	51	40
6500	10000	500	277	196	160	139	113	98	88	88	80	62
10000	16000	800	444	314	256	222	181	157	140	140	128	99
16000	25000	1300	721	510	416	361	294	255	228	228	208	161

¹⁾ LP standard measuring ranges 1:20 and 1:30 (on request)

²⁾ Measuring range 1:10

To get the Q_{min,LP} value for defined values of the operating pressure and for other gas types you can calculate it using the formula on page 4 or you can contact RMG.

Overview of the materials used

Designation	Material
Meter case	GGG40, cast steel or welded steel
Flow straightener	Delrin, aluminium or steel
Turbine wheel	Delrin or aluminium
Measuring element case	Aluminium
Measuring element bearings	Aluminium and/or stainless steel
Ball bearings	Stainless steel
Shafts	Stainless steel
Gearing	Stainless steel or plastic
Magnetic coupling	Stainless steel
Meter head	Aluminium
Totalizer	Plastic
Meter board	Aluminium, die-cast zinc or brass

Annex

German certificate of conformity for the LF and HF sensors