

Turbine meter TRZ 03-L



RMG Meßtechnik GmbH

P.O.Box 280 · D-35502 Butzbach (Germany)
Phone: +49 (0)6033 897-0 · Fax: +49 (0)6033 897-130
E-mail: messtechnik@rmg.de · Web site: <http://www.rmg.de>



Publication No. 3.162-E

Reliability in gas supply -
single-sourced across the board

Method of operation

The TRZ 03-L turbine meter is a flow meter suitable for custody transfer flow measurement, where the rate of flow is indicated by a mechanical totalizer in units of volume (cubic meters at flowing conditions) under prevailing pressure and temperature.

The gas flow is constricted to a definite cross section and drives a coaxially mounted turbine wheel. The speed of the turbine wheel, which is proportional to the flow rate, is reduced by gearing and transmitted to the mechanical digital index.

Construction

A perforated plate is located directly at the meter inlet, which - together with the flow straightener fitted directly in front of the measuring element - substantially eliminates turbulences and swirl from the gas flow. Furthermore, the flow straightener directs the gas onto the turbine blades.

The rotary motion generated by the turbine wheel is transmitted by a magnetic coupling from the pressurized meter case to the unpressurized meter head.

The number of rotations is reduced by gearing in the meter head, which can be adjusted by selecting an

appropriate pair of adjusting gears, so that cubic meters at flowing conditions are indicated by the mechanical totalizer. A reed contact (or an inductive sensor) located on the mechanical totalizer provides low-frequency pulses whose number is proportional to the volume at actual conditions flowed through.

Inductive high-frequency sensors scan the turbine wheel (HF 3) and the reference wheel (HF 2). The latter is a cam wheel located on the same shaft as the turbine wheel, which enables the turbine wheel to be monitored.

The specific arrangement with the perforated plate and the measuring element fitted further in the rear enables the TRZ 03-L to be installed without an additional inlet pipe.

Approvals

The TRZ 03-L turbine meter has been approved by PTB for **custody transfer flow measurement** and tested by DVGW. The reference numbers for approval are as follows:

EU approval:	D 98.7.211.19
Domestic approval:	7.211/98.11
DVGW product ident No.:	CE-0085BN0291

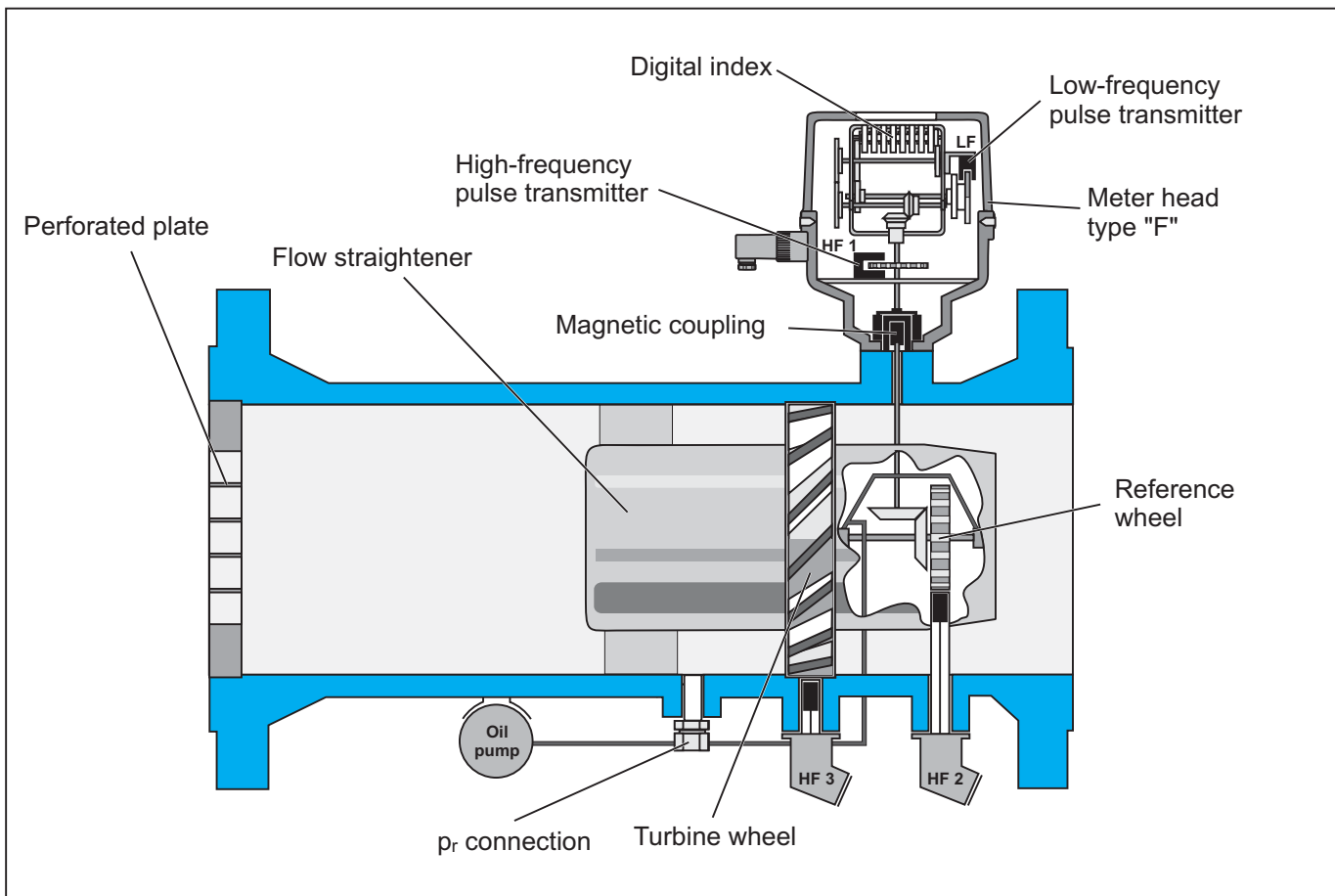

Features

No inlet pipe required

LF pulse transmitter (in the meter head)

Standard: reed contact
 Alternatively: inductive pulse transmitter
 Option: up to 3 LF pulse transmitters possible

HF pulse transmitter (option)

- In the meter head:
 Inductive pulse transmitter (HF 1), pulse frequency at Q_{max} approx. 100 Hz.
- In the meter case:
 Inductive pulse transmitters for scanning
 - the blades of the turbine wheel (HF 3, from DN 80)
 - the cams of the reference wheel (HF 2, from DN 250)

All inductive pulse transmitters provide volume pulses in compliance with NAMUR.

Meter head (type "F")

- Protection class: IP 65
- Universally readable
- Totalizer unit and HF1 pulse transmitter are easily replaceable on site.

Measuring range: up to 1:30

With high-pressure testing, an expansion up to 1:50 is possible.

Nominal sizes: DN 50 through DN 600

Pressure rating: PN 10 through PN 100, ANSI 150 through ANSI 600

Special designs with a higher pressure rating are possible.

Operating temperature range

Standard design: -10°C to $+50^{\circ}\text{C}$

Special designs for higher and/or lower temperatures are possible.

Explosion protection

The pulse transmitters are intrinsically safe; their type of protection is EEx ib IIC T6. Therefore, the TRZ 03-L can be operated in Zone 1.

Long service life

pr. connection

To connect the pressure transmitter of a PTZ corrector.

Thermowell inside the meter case (option)

To accommodate a resistance thermometer.

Inspection report

In compliance with EN 10204/3.1B, for strength and leak testing.

Accuracy

Error limits (standard):

$\pm 2.0\%$ for Q_{min} to $0.2 Q_{max}$
 $\pm 1.0\%$ for $0.2 Q_{max}$ to Q_{max}

These limits (calibration error limit) apply for low pressure ranges. For an operating pressure above 4 bar, half the calibration error limit is reached.

Higher accuracy available on special request.

Repeatability: $\pm 0.1\%$

All gas meters are tested in the factory with air under atmospheric pressure.





Materials

Rotor:

Delrin for DN 50 to DN 200 and PN 10 / PN 16.
 Aluminium alloy for all other diameters and pressure ratings and for meters with HF sensors.
 Aluminium rotors instead of delrin rotors on special request.

Meter case material (standard):

	PN						ANSI		
DN	10	16	25	40	64	100	150	300	600
50	Steel	Steel	Cast steel	Steel, welded	Steel, welded	Steel, welded	Steel, welded	Steel, welded	Steel, welded
80	Steel	Steel	Cast steel	Steel, welded	Steel, welded	Steel, welded	Steel, welded	Steel, welded	Steel, welded
100	Steel	Steel	Cast steel	Steel, welded	Steel, welded	Steel, welded	Steel, welded	Steel, welded	Steel, welded
150	Steel	Steel	Cast steel	Steel, welded	Steel, welded	Steel, welded	Steel, welded	Steel, welded	Steel, welded
200	Steel	Steel	Cast steel	Steel, welded	Steel, welded	Steel, welded	Steel, welded	Steel, welded	Steel, welded
250	Steel	Steel	Cast steel	Steel, welded	Steel, welded	Steel, welded	Steel, welded	Steel, welded	Steel, welded
300	Steel	Steel	Cast steel	Steel, welded	Steel, welded	Steel, welded	Steel, welded	Steel, welded	Steel, welded
400	Steel	Steel	Cast steel	Steel, welded	Steel, welded	Steel, welded	Steel, welded	Steel, welded	Steel, welded
500	Steel	Steel	Cast steel	Steel, welded	Steel, welded	Steel, welded	Steel, welded	Steel, welded	Steel, welded
600	Steel	Steel	Cast steel	Steel, welded	Steel, welded	Steel, welded	Steel, welded	Steel, welded	Steel, welded

Steel  Spheroidal cast iron 
 Cast steel  Steel, welded 

Any material available on special request.

Pressure loss

The pressure loss Δp stated in the table applies to natural gas at Q_{\max} and 1 bar. From this, the pressure loss at actual conditions can be calculated using the following formula:

$$\Delta p_A = \Delta p \cdot \frac{\rho_N}{0.83} \cdot p_A \cdot \left(\frac{Q_A}{Q_{\max}} \right)^2$$

Δp_A = Pressure loss at actual conditions (p_A , Q_A) in mbar

Δp = Pressure loss at Q_{\max} with natural gas at 1 bar in mbar (see table)

ρ_N = Standard density of the gas in kg/m³

p_A = Operating pressure in bar (absolute)

Q_A = Flow rate at actual conditions in m³/h

Q_{\max} = Maximum flow rate in m³/h (see table)

Example:

Air, $\rho_N=1.29$ kg/m³, nominal meter size DN 100,

$Q_{\max} = 400$ m³/h, $p_A=1.1$ bar(a), $Q_A=250$ m³/h.

Take from the table: $\Delta p=5$ mbar

Hence:

$$\Delta p_A = 5 \cdot \frac{1.29}{0.83} \cdot 1.1 \cdot \left(\frac{250}{400} \right)^2 \text{ mbar} = 3.3 \text{ mbar}$$

Nominal size DN		Max. flow rate Q_{\max} m ³ /h	V_{LF}^* m ³	Δp mbar	HF pulse transmitter (option)	
mm	in.				HF2	HF3
50	2"	100	0.1	6	-	-
80	3"	160 250	1 1	2 7	-	•
100	4"	250 400	1 1	2 5	-	•
150	6"	650 1000	1 1	2 7	-	•
200	8"	1600	10	4	-	•
250	10"	1600 2500	10 10	2 4	○	•
300	12"	4000	10	5	○	•
400	16"	6500	10	4	•	•
500	20"	10000	10	5	•	•
600	24"	16000	100	5	•	•

* V_{LF} : Volume at actual conditions per LF pulse

- not available

○ not available for all pressure classes

• available for all pressure classes

Pulse outputs

The meter head is fitted with a reed contact as LF pulse transmitter as standard feature. But optionally, another two sensors can be fitted, e.g. another LF pulse transmitter (inductive sensor with output pulses complying with NAMUR or reed contact) and an HF1 pulse transmitter (NAMUR).

Connection is made by means of a 7-pin Binder plug:

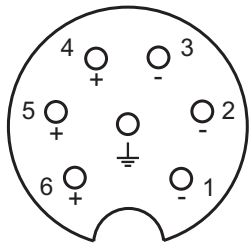

1, 4: LF (reed contact)

2, 5: LF or HF1 signal

3, 6: HF1 (NAMUR)

If only one LF pulse transmitter is fitted, it is always connected to the contacts 1 and 4; a single HF1 pulse transmitter is always connected to the contacts 3 and 6.

If high-frequency pulse transmitters (with output pulses complying with NAMUR) are fitted which scan either

the turbine wheel (HF3) or the reference wheel (HF2), each of them is connected separately using a Binder plug at the front of the device:

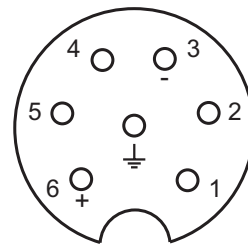

3, 6: HF2 or HF3 signal

The contacts 1, 2, 4 and 5 are not assigned.

All pulse transmitters are intrinsically safe and may be connected only to certified intrinsically safe circuits for use in areas subject to explosion hazards.

Maximum pulse transmitter frequencies:

LF: 0.3 Hz

HF1: 300 Hz

HF2: 2.1 kHz

HF3: 2.1 kHz

The phase displacement between the signals from the HF2 and HF3 pulse transmitters is 180°.

Types of gas

The TRZ 03-L standard design is suitable for use with all gases in compliance with the DVGW code of practice G260. The materials used are appropriate for gases and fuel gases, such as natural gas, refinery gas, gaseous liquid gases and their mixtures, nitrogen, CO₂ (dry), air and all inert gases.

For aggressive gases (e.g. biogas, acid gas or ethylene), there are special designs available with PTFE lining, special material, special lubrication, etc.

Maintenance

All turbine meters are fitted with a lubricator (DN 50 and DN 80: oil nipple or pushbutton pump; DN 100 through DN 200: pushbutton pump; from DN 250: lever pump).

Lubrication must be performed in compliance with the operating instructions (see also the lubrication instruction plate of the gas meter). If clean gas is used, lubrication is to be performed at 3-month intervals, whereas lubrication must be performed more frequently if dust- and/or condensate-laden gas is used.

Mounting and operating instructions

The TRZ 03-L turbine meters can be operated in any mounting position up to the nominal size of DN 200. From the nominal size of DN 250, they can only be installed in a horizontal position.

Special instructions for startup and operation:

Turbine meters are precise measuring instruments and must therefore be carefully handled during transport, storage and operation.

Do not fill any downstream pipelines or station sections via the turbine meter. This may result in excessive flow rates with resultant damage to the turbine wheel.

The gas meter has been designed for short-term overload operation at up to 1.2 times the value of Q_{max} . Such load conditions should be avoided, however, in order to protect the TRZ 03-L from any unnecessarily high flow rates.

The gas flow must be free of foreign particles, dust or liquids. Otherwise it is recommended that filters and separators be installed.

The TRZ 03-L turbine meter requires no additional inlet pipe, even if there is a heavy flow perturbation due to a gas pressure controller, for example. The TRZ 03-L was tested without inlet pipe in compliance with the Technical Guideline G13 (equivalent to the OIML guideline IR-32/89).

The outlet pipe must be of the same nominal size as the gas meter and must be at least 2 DN long. A bend may also be fitted as outlet pipe.

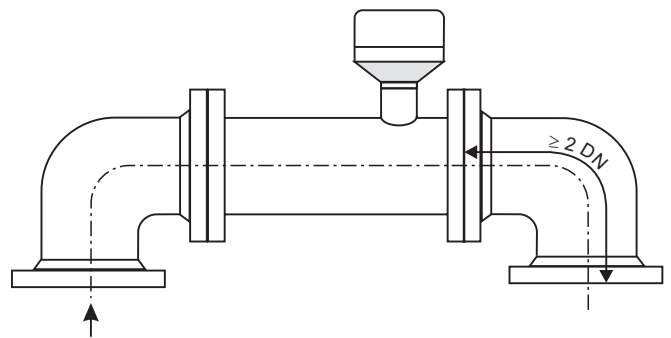

The gas meter must be installed in weather-proof locations. For outside installations, appropriate guards must be provided against direct weathering influences.

Order information

- Nominal size of the pipeline
- Size G
- Operating pressure (min/max) in bar g or bar a
- Operating temperature (min/max)
- Ambient temperature (min/max)
- Type of gas to be used
- Pressure rating and DIN or ANSI flange design
- Direction of flow / mounting position
- Accessories: e.g. volume corrector
- Options: HF pulse outputs, etc.
- Special designs, e.g. for aggressive gases

Turbine meter

TRZ 03-L

Measuring ranges, dimensions, weights

DN mm in.	Size	Measuring range (m ³ /h)			Approx. weight (kg) Pressure rating										Dimensions mm		
		Q _{min}		Q _{max}	PN										H	C	L
		1:20	1:30		10	16	25	40	64	100	150	ANSI 300	600				
50 2"	G 65	10 ¹⁾	-	100	13	13	21	21	21	21	13	13	21 ²⁾	250	28	150	
80 3"	G 100 G 160	16 ¹⁾ 13	- -	160 250	20	20	25	25	34	34	20	25	36	270	40	240	
100 4"	G 160 G 250	13 20	- -	250 400	25	25	32	32	45	45	30	35	55	290	50	300	
150 6"	G 400 G 650	32 50	- 32	650 1000	50	50	60	60	70	90	50	65	100	325	80	450	
200 8"	G 1000	80	50	1600	75	75	95	95	150	160	100	120	160	290	120	600	
250 10"	G 1000 G 1600	80 130	- 80	1600 2500	100	110	135	150	180	225	110	160	260	330	165	750	
300 12"	G 2500	200	130	4000	140	155	230	270	280	295	160	235	315	360	200	900	
400 16"	G 4000	320	200	6500	290	300	360	450	535	590	360	470	585	400	300	1200	
500 20"	G 6500	500	320	10000	575	625	655	715	845	1075	635	665	1090	450	385	1500	
600 24"	G 10000	800	500	16000	925	965	1000	1100	1250	1590	975	1025	1625	500	480	1800	

¹⁾ Measuring range 1:10

²⁾ Monoflange design

From DN 80 to DN 300, the turbine meters with a pressure rating of PN 10/16 can be fitted with a thermowell to accommodate a temperature sensor.

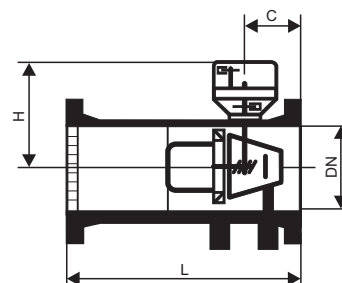

RMG Meßtechnik GmbH



Publication No. 3.162-E

P.O.Box 280 · D-35502 Butzbach (Germany)
Phone: +49 (0)6033 897-0 · Fax: +49 (0)6033 897-130
E-mail: messtechnik@rmg.de · Web site: <http://www.rmg.de>

Issue: 05/2005 · Subject to technical modification without notice