

# Gas Odorization System GOE-SO-1

Special design



**RMG Meßtechnik GmbH**

P.O.Box 280 · 35502 Butzbach (Germany)  
Tel: +49 6033 897-0 · Fax: +49 6033 897-130  
E-Mail: [messtechnik@rmg.de](mailto:messtechnik@rmg.de) · Internet: <http://www.rmg.de>



Serving the Gas Industrie  
- WORLDWIDE

## Method of operation

In order to immediately detect natural gas leaking, it is necessary to add an odorous substance (odorant) to the odourless natural gas. Special devices adding the odorant in the required concentration are used for this process, which is called odorization.

The GOE -SO-1 odorization system operates according to the injection method. An electromagnetically operated reciprocating diaphragm pump injects the odorant into the gas flow. The proportioning pump receives an electric pulse from the associated control unit and then performs a stroke which delivers a settable quantity of odorant. The number and sequence of pulses are determined by the control unit on the basis of volume-proportional pulses received from a volumetric meter.

The special version GOE-SO-1 differs basically from the standard models GOE 07 and GOE 2000 by the fact that the odorant is drawn directly from a stationary tank from which it flows to the pump by gravity, whereas with both standard models the odorant is drawn out of a interchangeable tank by low pressure or gets to the pump according to the principle of communicating vessels.

## Construction

The individual components are fixed to a mounting plate which is installed above a collector. The stationary odorant tank is also located on the collector.

In the basic version the system contains one pump but it can be equipped with up to 3 pumps which press the odorant into the gas pipe. The odorant flows directly to the pump, caused by gravity. The system operates without vacuum and therefore no problems with the vapour pressure of the odorant appear. By the uncomplex construction with little piping there are few fittings (Swagelok) where leakages can appear.

An activated carbon filter prevents odorant from escaping to the outside when the system is vented.

For monitoring purposes, the system can be equipped with a level switch (giving an alarm when the level falls below minimum) or a level detector (level measurement).

Every gas odorization system incorporates a control unit which is normally installed in the safe area. Depending on the desired functional range an elementary device for the basic functions can be used or a device based on a stored-program controller.

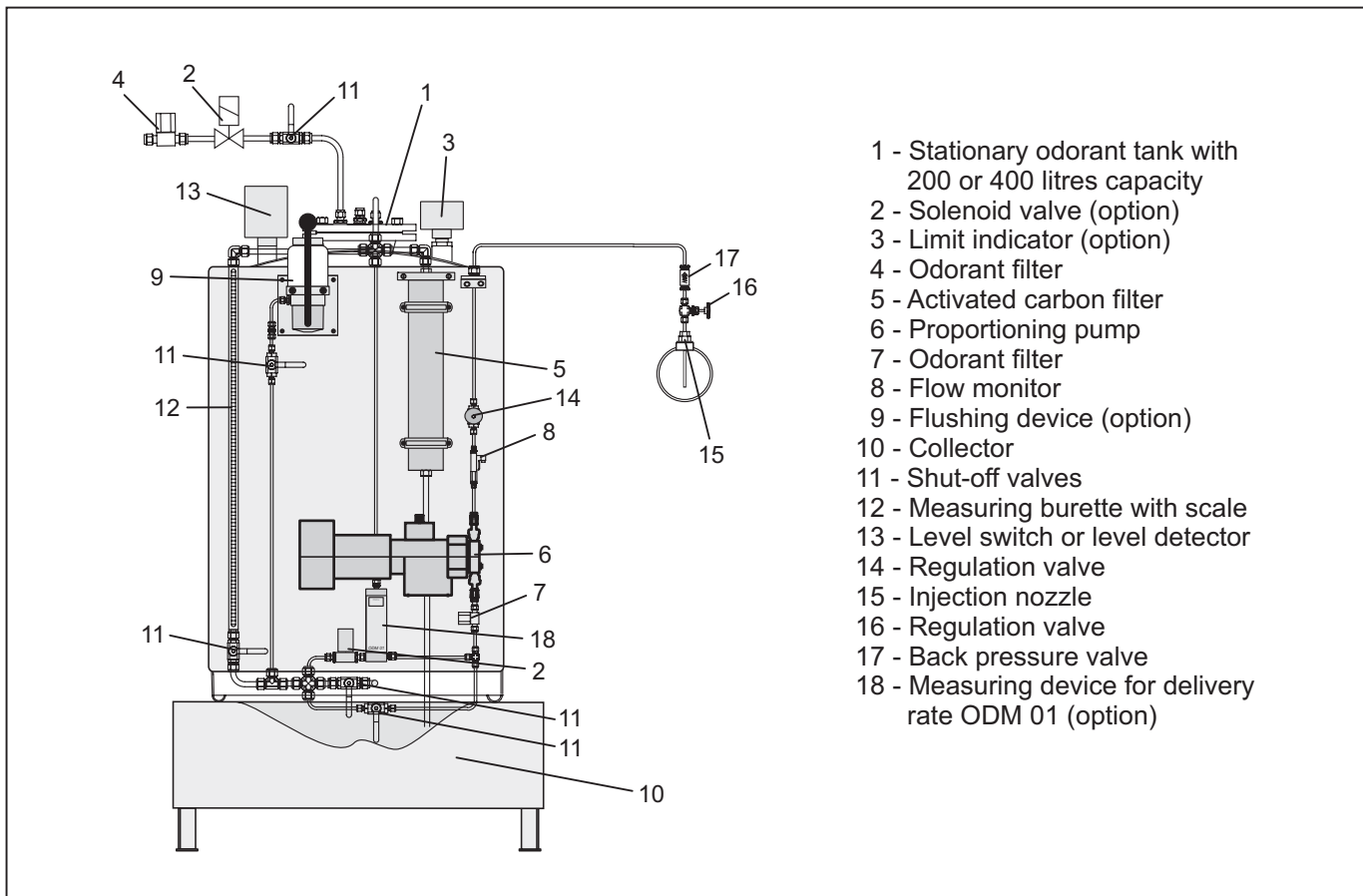

## Features

- **Odorizes according to the injection method**  
Injection is performed by a reciprocating diaphragm pump which is controlled by volume-proportional pulses.
- **Odorant is drawn from the odorant tank by gravity**  
No auxiliary pressure is required (neither overpressure nor underpressure). The method is independent of the vapour pressure of the odorant and therefore suitable for all current odorants.
- **High proportioning accuracy**  
In this way, a constant odorant concentration is achieved in the gas flow.
- **Wide operating range**  
Further extension of the operating range by 1 or 2 additional pumps.
- **High level of reliability**  
All parts coming into contact with the odorant are manufactured from stainless steel, glass and suitable sealing materials.
- **Infinitely variable setting of the odorant concentration**  
The setting of the odorant concentration can be performed at the pump and is also possible during operation.
- **Suitable for use with all common odorants**  
e.g. for THT or mercaptans
- **Installed on a mounting plate with SWAGELOK fittings ready for connection**
- **Odorant tank can be filled without interrupting operation**
- **Venting the pump head poses no problems even if the gas line is under pressure**
- **Low on maintenance**
- **Equipped with a stored-program control unit**
- **Convertible to sulfur-free odorant (option)**
- **Measuring device for delivery rate (option)**

## Control units

- **7-IG 4**  
An elementary control unit for the basic functions in a wall-mounting case.
- **7-EU 4**  
Like 7-IG 4, but for installation in a 19" subrack.
- **OSG 2000-W**  
Control unit with modular structure, based on a stored-program controller, in a wall-mounting case.
- **OSG 2000-E**  
Like OSG 2000-W, but for installation in a 19" subrack.
- **OSG 2000-M**  
Like OSG 2000-W, but operating unit and control unit are installed in different places.

## Options

- **Level switch** giving an alarm when the filling level falls below a preset minimum value.
- **Overflow controller**, built in the odorant tank, consisting of a limit value transmitter and a solenoid valve in the filling pipe.
- **Flow monitor** installed in the injection pipe for monitoring the proportioning pump.
- **Measuring device for delivery rate** for precise measurement of the quantity of injected odorant.

- **Level detector** for continuous level measurement.
- **High-pressure flushing and venting device** for flushing the fittings installed in the suction and injection pipes and for venting the proportioning pump. Maximum gas back pressure: 80 bar.
- **Manual button** (EEx i or EEx d), including manual/automatic changeover, for manual pump control.

## Accessories

- **Injection nozzle** for injecting the odorant into the gas flow, including a non-return valve and a manual stop valve. There are different lengths available for nominal pipe diameters from DN 50 to DN 800.
- **Weldolet** (PN 100) for installing the injection nozzle, with G $\frac{1}{2}$ ", G $\frac{3}{4}$ " or G1" internal thread.
- **Collector** made of stainless steel with grid and supporting feet, manufactured and tested in compliance with WHG (100 litres or 200 litres).
- **Weather-proof concrete cabinet** with separate, gas-tight electrical section for installing the GOE-SO-1 odorization system with odorant tank, collector and control unit.
- **Insulating coupling** for the injection pipe, dia. 6 mm, for the electrical isolation of the piping and the odorization system.

